



 A KEE SAFETY COMPANY

Steel Connection Solutions



- HOLLOW SECTION, STEEL CLAMPING, STEEL FLOORING AND BUILDING SERVICES CONNECTIONS
- NO SPECIAL TOOLS OR SKILLED LABOR REQUIRED
- NO SITE DRILLING OR WELDING REQUIRED
- THIRD PARTY APPROVALS

Beam Clamp®

 A KEE SAFETY PRODUCT

Box Bolt®

 A KEE SAFETY PRODUCT

LNA Solutions - serving the US market since 1995

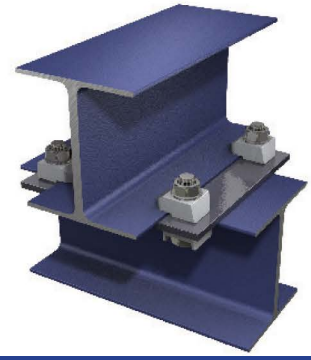
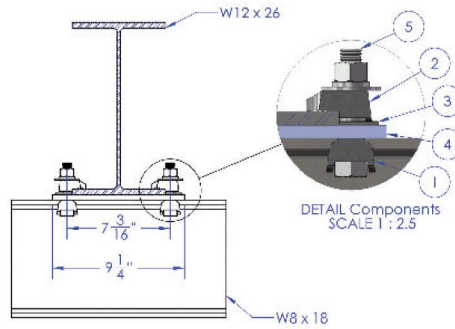

Our name was changed to LNA Solutions to better reflect the way we do business. We don't just sell you the components, we provide technical design solutions for any steel connection challenge you encounter. Our sales team and qualified engineers will give you first class service and ensure you receive custom designs to meet your needs, with no additional cost to you. Every job is designed and checked to ensure full compliance with your specifications. Before shipping, every order is double checked to ensure you don't encounter a shortage on-site.

Quality Service

LNA Solutions has now taken service to a new level. We are not just a distributor, but now own our supply chain from foundry to warehouse. We control the manufacturing process, ensuring the quality of our products; we control our inventory, ensuring product availability; and we control our pricing, ensuring great value for your money.

Solutions

Our BeamClamp® range is extensive, and we continue to add new products, developing and enhancing items to meet our customer's needs. LNA Solutions is North America's leading steelwork connection company, based in Ann Arbor, Michigan. If you have a question or an application problem, call us, and we'll deliver the solution.

The BeamClamp® and BoxBolt® range of clamps are a series of products that provide a secure clamping method for structural steel. The clamps provide solutions for joining steel without the need for on-site drilling or welding, giving much more flexibility than traditional methods. The system provides a guaranteed connection every time without the need for on-site verification, providing the installation guidelines are correctly followed.



Features & Benefits

- Peace of mind for the specifier
- Savings in installation time and cost
- No on-site drilling or welding
- Long term corrosion resistance
- No special tools or skills required
- Hot Dip Galvanized finish
- 5 to 1 Factor of Safety
- Third party approvals



Contents

4 Markets & Applications



Cavity Solutions

- 6 BoxBolt® Technical
- 8 BoxBolt® Installation
- 9 BoxBolt® Applications
- 10 Cost Analysis for BoxBolt®

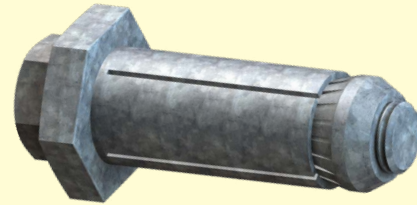

Steel Connection Solutions

- 11 BeamClamp® Intro/Technical
- 12 Standard Clamp Components
- 19 Location Plates & Bolt Lengths
- 20 High Friction Components
- 21 BBLN Components
- 23 Applications
- 26 Specifying the Correct Product
- 29 Connection Designer
- 30 Cost Analysis for BeamClamp®
- 32 Rigging Clamps
- 34 Fast Fit

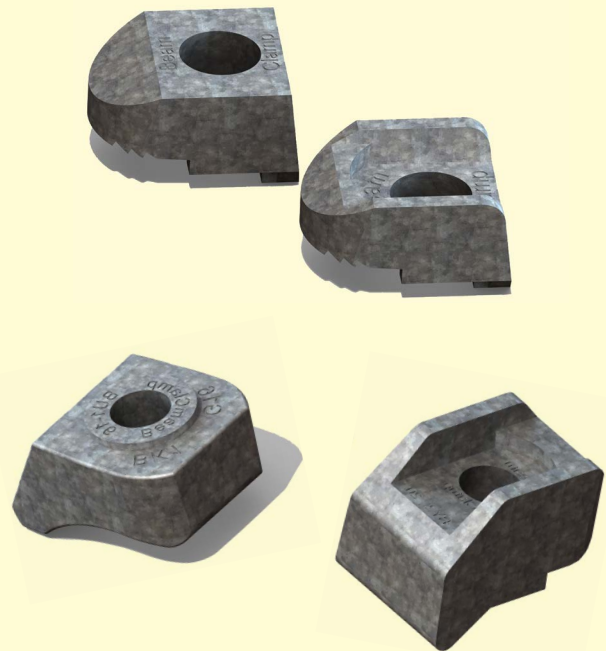

Floor Solutions

- 36 FloorFix HT & FloorFix
- 38 Gratefix & Grating Clip
- 40 G-Clip
- 41 Testing



Service Support Solutions

- 42 Types BL, BV, BU
- 43 Applications



Markets & Applications

BEAMCLAMP and **BOXBOLT** products can be used across all industries that require joining steel together and therefore can be applicable for almost any market. The examples below are some of our most common applications and industries that we are involved in.



Infrastructure



BeamClamps are used for a variety of applications within the civil sector for rail, road, water treatment plants and in power generation. These applications are usually for attaching secondary steelwork to existing infrastructure. Applications on bridges would include the installation of strengthening steelwork, walkway systems and the suspension of services to the bridge structure. On Water treatment plants our BeamClamps are used for securing guardrail to protect the filtration tanks in addition to many other applications.

Steel Construction



Within the structural sector our products are used extensively for the connection of structural steel for both permanent or temporary situations. Our clamps are commonly used for secondary steel or temporary applications when no damage to the existing structure is permitted. They are also used when flexibility of installation is important, hazards from drilling or welding are apparent and access is difficult for power and heavy machinery. Typical applications would include the connection of runway beams for walkways, connecting cladding, securing steel flooring, connecting ballustrading and strengthening of open steel joist frames.

Solar & Wind Energy



BeamClamp and BoxBolt products are used in the solar and wind energy sector extensively. Our clamps are used for securing solar panels to supporting frames and for securing brackets to existing structures that will in turn support the solar panels. Within the wind sector, a variety of our products are utilized on wind turbines. Typical applications would be the use of our Floorfix and Gratefix for securing steel flooring and grating on the inside of the platforms.



Building Services



A range of BeamClamp products are suitable for use within the building services industry. We have a variety of solutions for the connection of building services equipment to steel structures without the need to drill or weld to the structure. Applications would include the connection of mechanical services (pipe work), Heating Ventilation and Air-Conditioning systems, electrical services and fire protection services.

Facades and Curtain Walling



BoxBolts and BeamClamps are used in the facade and curtain walling sectors extensively. BoxBolts provide a solution for the connection of curtain walling brackets to hollow structural sections. Our BeamClamps also offer a clamping solution for securing curtain walling or cladding supports to the existing structure without the need for drilling or welding.

Oil and Gas/Processing Plant



BeamClamp products are extensively used offshore. The majority of the applications connect new steel to existing structures. The major benefit being that no drilling or welding is required on site and in most applications hot work is forbidden, therefore clamping is the ideal solution. All products across the range can be used for applications such as pipe supports, monorail systems, flooring sections, blast walls and helideck expansions.

Material Handling & Conveyors



BeamClamp products are extensively used for material handling applications due to their flexibility and their ability to be removed without damaging existing steel. These can be temporary solutions such as lifting points or more permanent solutions connecting conveyor supports that can then be relocated if required. Common applications would also be the installation of runway beams for cranes to existing steel and free-standing frames for gantry cranes.

Stadiums & Amphitheatres

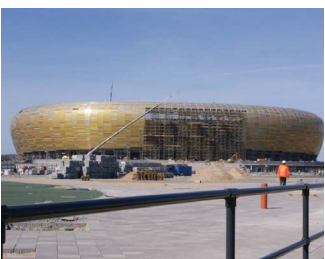

Our products are used within steel structured stadiums and amphitheatres for a variety of applications. BeamClamps are used for attaching secondary brackets to the existing steel for floodlights, display screens, tannoy systems and general building service equipment. BoxBolts are also used for the connection of guard railing, securing of steel flooring and the connection of seating to the supporting structure.



BoxBolt is a fully tested and approved blind connection solution for connecting to hollow section steel or where access is restricted to one side only. The **BoxBolt** is suitable for use with rectangular, square and even circular hollow sections. The features a hexagon head design to aid installation with a standard wrench. It allows it to be installed with our unique **BoxSok™** installation tool for when installation time needs to be kept to an absolute minimum.

The **BoxBolt** is available in three finishes; Zinc Plated for the less aggressive environments, Hot Dip Galvanized for the more aggressive environments, and Stainless Steel for the most demanding of applications. These finishes combined with three lengths of **BoxBolt** make it extremely flexible to suit its environment and application. The **BoxBolt** is approved for use by **Lloyds Register (LR)** type approval and the **Deutsches Institut für Bautechnik (DIBt)** to give the specifier and user total confidence.

BoxBolt® Technical Data

Select the type of finish you require on the **BoxBolt** by replacing the “_” in the code with a **Z** for zinc plated, a **G** for Hot Dip Galvanized or an **S** for Stainless Steel.

Example: **BQ2G12** is a **1/2” BoxBolt size 2** in **Hot Dip Galvanized** Finish.

Part Number & Description			Dimensional Information							Load Information		
Product Code	Bolt Dia	Description	Setscrew Length	Clamping Range (X)		Across Flats of Shoulder	Shoulder Thickness	Sleeve Dia	Hole Size Dia	Available Strength (lbs)		Torque (ft lb)
				Min	Max					Tensile	Shear	
BQ1Z06*	1/4"	1/4" BoxBolt Size 1	1-3/4"	1/8"	7/8"	11/16"	3/16"	3/8"	7/16"	2872	4793	14
BQ1_08	5/16"	5/16" BoxBolt Size 1	2"	3/16"	1"	7/8"	1/4"	1/2"	9/16"	5071	5917	18
BQ2_08	5/16"	5/16" BoxBolt Size 2	2-3/4"	11/16"	1-13/16"	7/8"	1/4"	1/2"	9/16"	5071	5917	18
BQ3_08	5/16"	5/16" BoxBolt Size 3	3-9/16"	1-3/16"	2-5/8"	7/8"	1/4"	1/2"	9/16"	5071	5917	18
BQ1_10	3/8"	3/8" BoxBolt Size 1	2"	3/16"	7/8"	15/16"	1/4"	11/16"	3/4"	9718	10985	33
BQ2_10	3/8"	3/8" BoxBolt Size 2	2-3/4"	11/16"	1-11/16"	15/16"	1/4"	11/16"	3/4"	9718	10985	33
BQ3_10	3/8"	3/8" BoxBolt Size 3	3-9/16"	1-3/8"	2-1/2"	15/16"	1/4"	11/16"	3/4"	9718	10985	33
BQ1_12	1/2"	1/2" BoxBolt Size 1	2-3/16"	3/16"	1"	1"	5/16"	3/4"	13/16"	13015	12676	59
BQ2_12	1/2"	1/2" BoxBolt Size 2	3-1/8"	3/4"	2"	1"	5/16"	3/4"	13/16"	13015	12676	59
BQ3_12	1/2"	1/2" BoxBolt Size 3	4"	1-9/16"	2-3/4"	1"	5/16"	3/4"	13/16"	13015	12676	59
BQ1_16	5/8"	5/8" BoxBolt Size 1	3"	3/16"	1-3/8"	1-7/16"	3/8"	1"	1-1/16"	26199	29578	140
BQ2_16	5/8"	5/8" BoxBolt Size 2	4"	1-3/16"	2-3/8"	1-7/16"	3/8"	1"	1-1/16"	26199	29578	140
BQ3_16	5/8"	5/8" BoxBolt Size 3	4-3/4"	2-3/16"	3-1/8"	1-7/16"	3/8"	1"	1-1/16"	26199	29578	140
BQ1_20	3/4"	3/4" BoxBolt Size 1	4"	5/16"	1-5/8"	1-13/16"	7/16"	1-1/4"	1-5/16"	36932	33804	221
BQ2_20	3/4"	3/4" BoxBolt Size 2	4-3/4"	1-3/8"	2-13/16"	1-13/16"	7/16"	1-1/4"	1-5/16"	36932	33804	221
BQ3_20	3/4"	3/4" BoxBolt Size 3	6"	2-9/16"	4"	1-13/16"	7/16"	1-1/4"	1-5/16"	36932	33804	221

* BQ1Z06 is tested at an external test house but is not approved by LR type or DIBt.

The loads stated above have a partial reduction factor of 0.75 applied to the ultimate tensile and shear strength to give the available strengths of the **BoxBolt**. A further reduction factor or factor of safety should be applied to these load values that is relevant to the application, code, or design guidelines. The overall strength of the connection is normally governed by the strength of material the **BoxBolt** is connecting into; therefore, the structural capacity of the connection should be checked by a structural engineer.

Approvals – The published loads are taken from physical testing in hollow structural section which are then verified by **Lloyds Register Type Approval**. The **BoxBolt** is also tested and approved by **DIBt (Deutsches Institut für Bautechnik)** which complies with the **DIN 18800** and **Eurocode 3** design methods for bolted steel connections. A design guide and calculator is available when using these methods. Please ask our technical team for more information.

BoxBolt® Technical Information

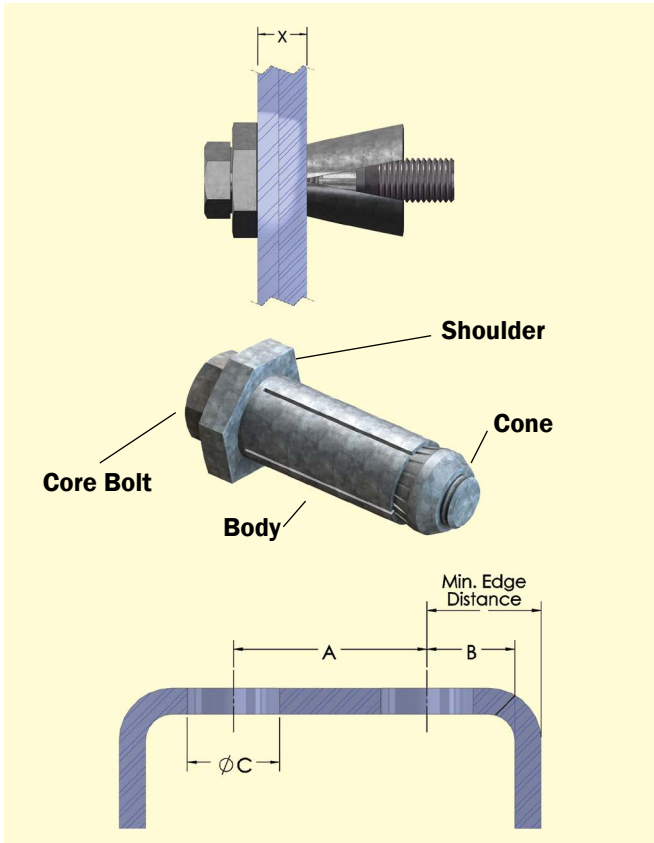

MATERIALS

Mild steel to **BS EN 10083** Grade **1.1151**

Stainless steel to **BS EN 10088** Grade **1.4401**

FINISHES

Zinc plated to **BS EN 12329** : Class **Fe//Zn8//A**

Hot Dip Spun Galvanized to **BS EN ISO 1461**

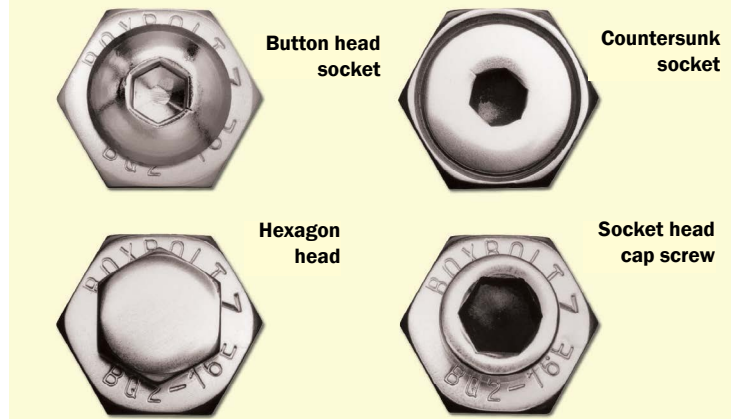

The **BoxBolt** is often used on high profile projects where the aesthetics of the building are essential. It is for this reason the **BoxBolt** can be adapted to suit the requirements of the Client and the Architect to make the connection pleasing to the eye. The most common versions we offer are shown above. Should you require a different style, please contact our technical department.

Hole Dimensions & Positioning

Box Bolt Size	Dim A	Dim B	Dim C
1/4	1-3/16	7/16	7/16
5/16	1-3/8	1/2	9/16
3/8	1-9/16	9/16	3/4
1/2	2	13/16	13/16
5/8	2-3/16	13/16	1-1/16
3/4	2-3/4	1	1-5/16

Minimum edge distance = Dim B + the thickness of hollow section

BoxSok™ Rapid Assembly Tool



The **BoxSok™ Installation Tool** is a rapid, unique assembly tool for the **BoxBolt**. This specially designed socket holds the hexagon shoulder on the body to stop rotating while allowing the inner socket to tighten up the core bolt. The core bolt draws the cone up inside the slotted body of the sleeve and expands the individual fins inside the connection. The **BoxSok™** eliminates the need for two tools to install the **BoxBolt**; this considerably speeds up the installation process and also reduces the risk of trapping hands between two tools. The **BoxSok™** device is available to suit all **BoxBolt** diameters.

Size	Overall Length	Body Length	Body Diameter	Drive Size
M06	4-5/16	3-3/8	1-3/16	1/4
M08	4-7/16	3-3/8	1-5/16	3/8
M10	4-7/16	3-3/8	1-1/2	3/8
M12	4-1/2	3-7/16	1-5/8	3/8
M16	4-1/2	3-7/16	1-15/16	1/2
M20	4-9/16	3-1/2	2-5/16	1/2

BoxBolt® Installation Instructions

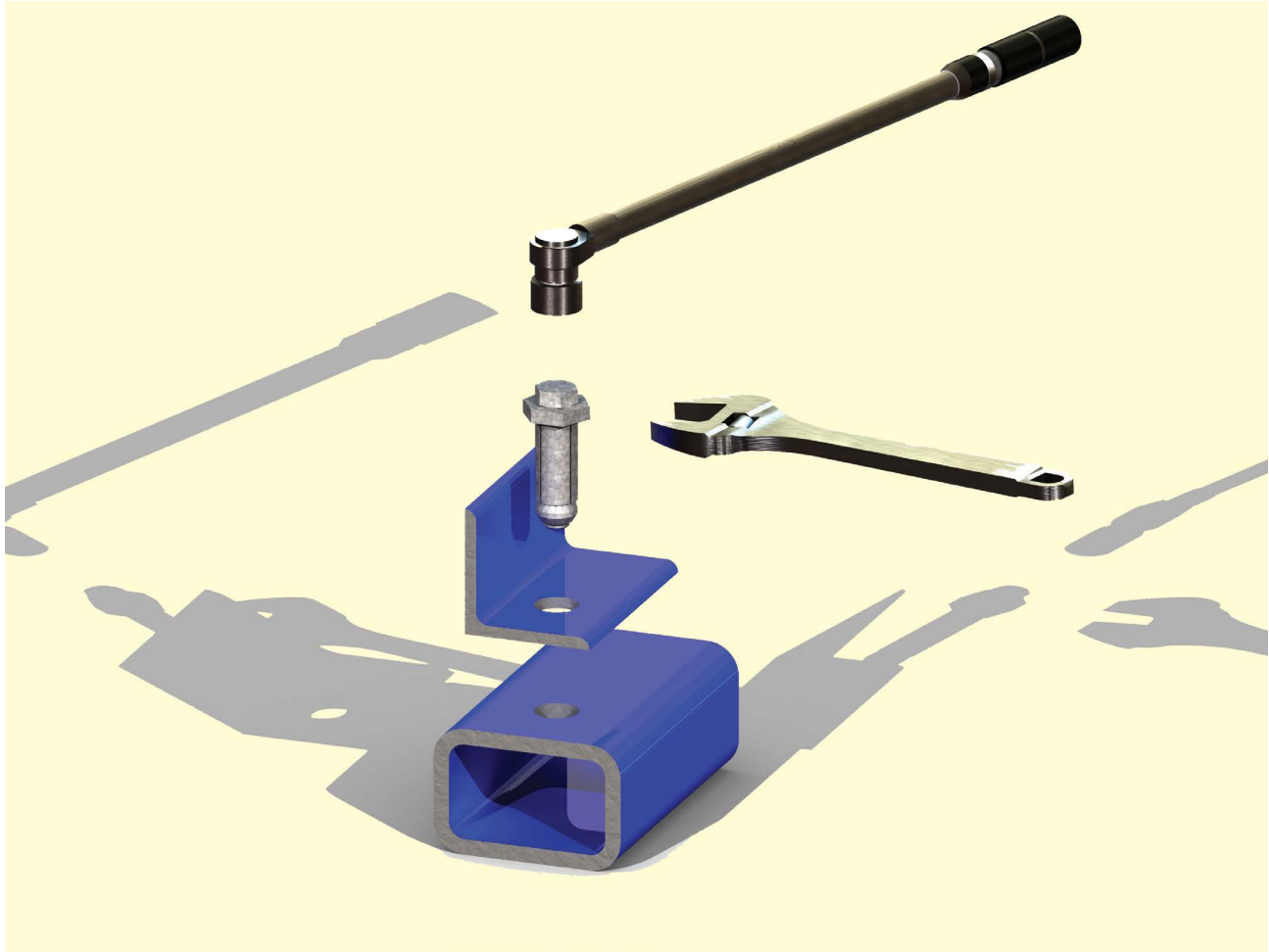

STEP 1: Align the holes in the bracket to be secured with the pre-drilled hole in the structural tube. Insert the BoxBolt through both pieces of steel until the underside of the shoulder is flush with the outside of the steel.

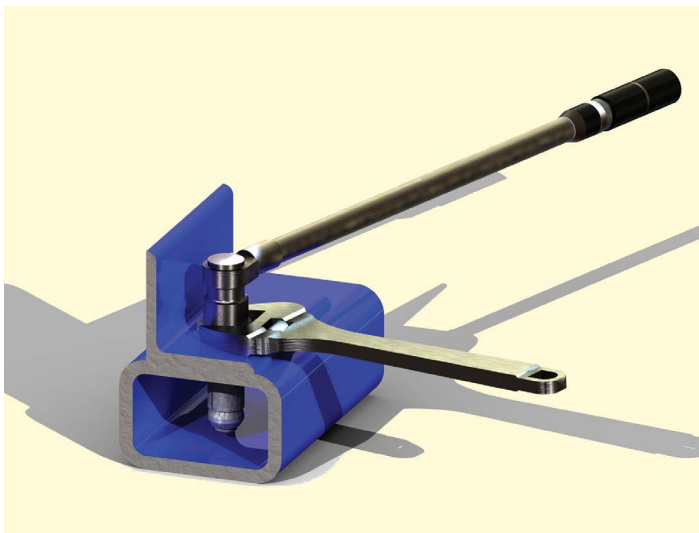

STEP 2: Hold the hexagon shoulder of the BoxBolt with an open ended wrench. Use an impact wrench or ratchet to tighten the core bolt.

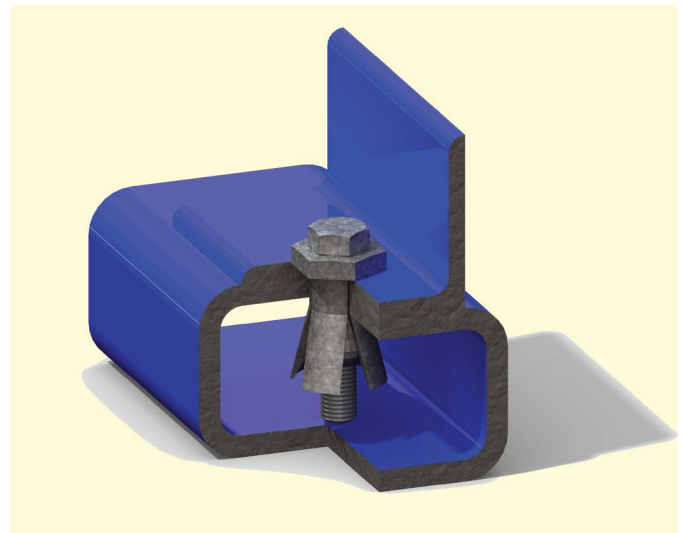

STEP 3: Remove the open ended wrench and check to ensure that the core bolt is tightened to the recommended torque.

BoxBolt® Application Examples

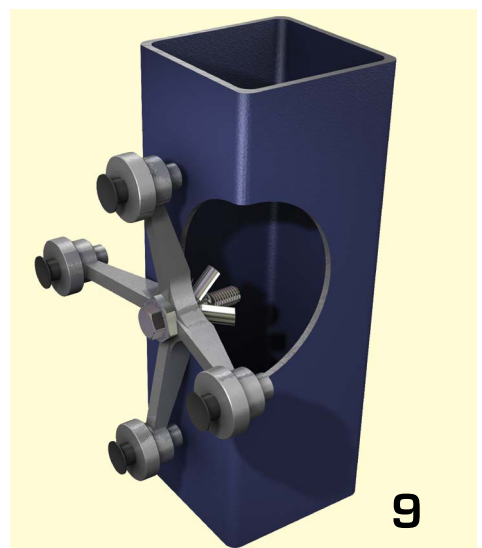
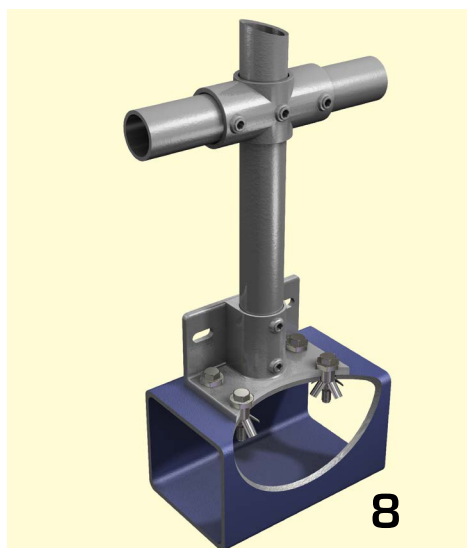
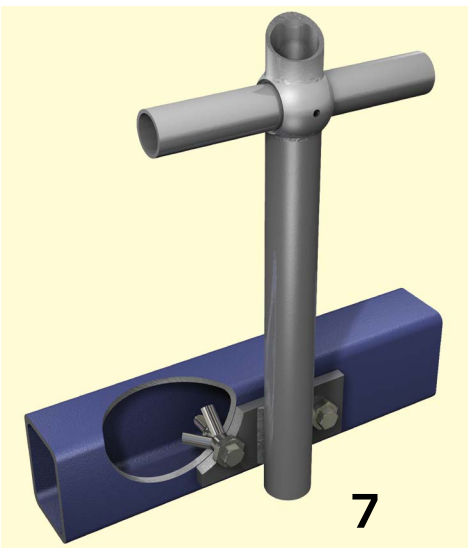
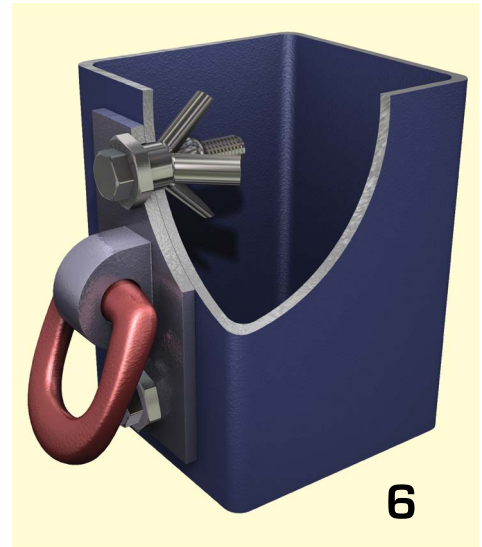
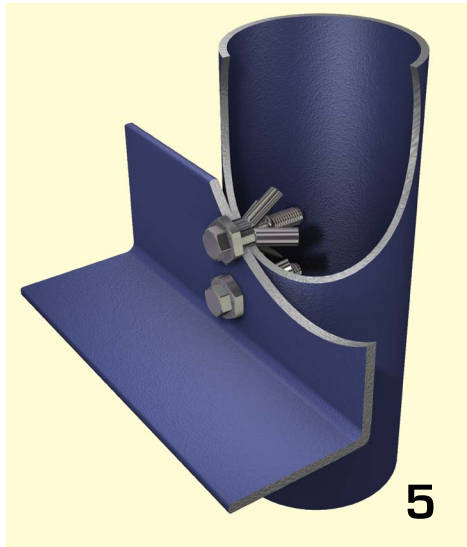
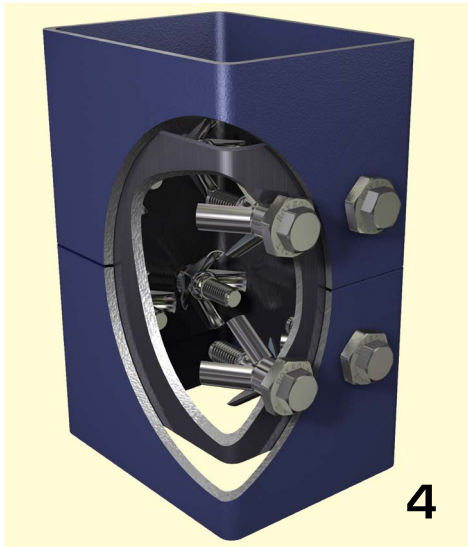
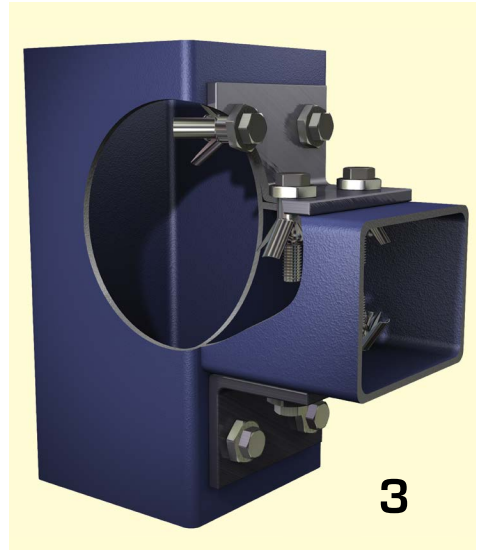
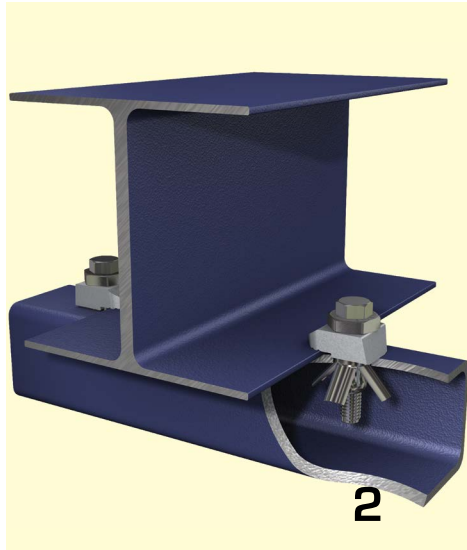
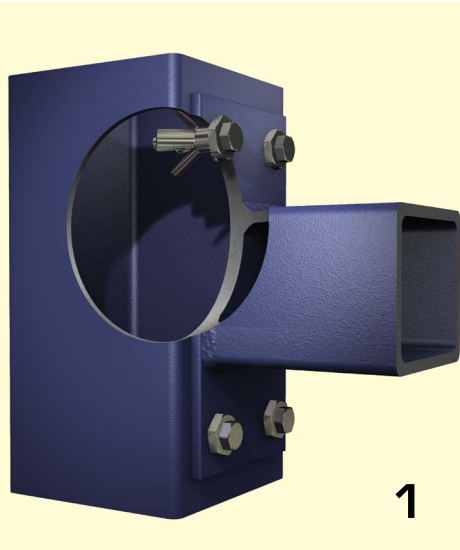

Cost Analysis for BoxBolt® vs. Traditional Methods

Traditional Drilled, Tapped & Bolted Method Cost Analysis

Based on pre-drilling the holes of the secondary steel member off site and drilling holes in the existing structure to match on site. The bolts will be 5/8" high tensile.

Connection Requirements	Rate/hr (\$)	Time (hrs)	Step Cost (\$)	Details of Each Step
Engineering	70	0.50	35	Detailing the positions and checking the integrity of the exiting steel after adding holes
Marking of Steel	40	0.50	20	The time required to mark the steel on site to ensure alignment with secondary member
Site Set Up	60	0.25	15	The time required to access power, get the drilling machine into position
Drilling Time on Site	60	1	60	Based on a steel thickness of 1/2" and 1/4 hr per hole
Tapping on Site	60	0.50	30	Half the time to tap
Tightening of Bolts	60	0.20	12	High torques required - allowing 5 minutes per bolt and nut
Drill bits/taps	N/A	N/A	30	1 Drill bit and 1 tap at \$15 each
Material Costs (Bolts)	N/A	N/A	16	Four bolts, nuts and washers @ \$4 each
Totals		2.95	\$218.00	

Traditional Welded Method Cost Analysis

Based on making a fully fillet welded connection of a new hollow section to an existing hollow section structure when both sections have a red oxide or hot dip galvanized corrosion protection.

Connection Requirements	Rate/hr (\$)	Time (hrs)	Step Cost (\$)	Details of Each Step
Engineering	70	0.25	17.50	Not much design work required apart from highlighting the position of weld
Apply for Hot Work Permit	50	0.50	25	The issue time is set at 30 mins - can be longer
Marking of Steel	40	0.25	10	The marking of the steel is at a minimum for a welded connection
Site Set Up	40	0.50	20	Time to move equipment, power cords and get machinery ready
Removal of Corrosion Protection	60	1.0	60	The whole area for the weld needs to be removed by grinding and is time consuming
Performing of Weld (inc. equipment)	110	1.0	110	Based on a certified welder and equipment to make the connection
Fire Watch during and after Weld	40	2.0	80	Fire watchers can be over longer periods but this is set at 2 hours of welding
Touch up of Galvanized Paint	40	0.33	13.20	Replacement of the galv paint will not be as good as the original finish
Non Destructive Testing	60	0.33	19.80	Testing of the weld required to prove load capabilities
Totals		6.16	\$355.50	

BoxBolt® Connection Cost Analysis

Based on making an end plate connection using four 5/8" BoxBolts. The hollow section column has a thickness of 1/2" (12.5mm) and therefore the BQ1G16 was selected.

Connection Requirements	Rate/hr (\$)	Time (hrs)	Step Cost (\$)	Details of Each Step
Engineering	70	0.25	17.50	Detailing the positions and checking the integrity of the exiting steel after adding holes
Marking of Steel	40	0.25	10	The time required to mark the steel on site to ensure alignment with secondary member
Site Set Up	60	0.25	15	The time required to access power, get the drilling machine into position
Drilling Time on Site	60	0.25	15	Based on a steel thickness of 1/2" and 1/4 hr per hole
Tightening of Bolts	60	0.20	12	High torques required - allowing 5 minutes per bolt and nut
Material Costs (Bolts)	N/A	N/A	80	Four BoxBolts (BQ1G16) @ \$20 each
Totals		1.2	\$149.50	

When all methods are compared BoxBolt® brings in an average minimum savings of **31%**





BeamClamp is an extensive range of clamping products designed for making steel to steel connections without the need for drilling or welding. The clamping system gives the specifier the peace of mind that once the connection is made it has a guaranteed safe working load and it also provides flexibility for the user when installing and reduces the overall cost. The system is also ideal for areas where drilling or welding are not allowed or access and power are restricted.

Features

- **Third party approvals (Lloyds & DIBt)**
- **Guaranteed 5 to 1 Factor of Safety**
- **No special tools or skilled labor required**
- **Hot Dip Galvanized as standard**
- **Easy to adjust on-site**
- **No weakening of existing steel**
- **No damage to protective coating of the steel**

Technical Support

We offer a full engineering service to support our products which includes recommendation of an individual product through to a full design capability for a large project. Our technical team has **2D/3D Computer Aided Design (CAD)** capabilities and can supply design engineers with specific application solutions. Our Technical Sales Engineers perform regular **Continuous Professional Development (CPD)** seminars to educate the design engineers on how to specify our clamping products.

Benefits

- **Peace of mind when specifying or installing**
- **Provides safe connections**
- **Savings in installation time and cost on-site**
- **Excellent long term corrosion resistance for external applications**
- **Provides flexibility to allow for site tolerances**
- **Structural integrity of steel remains unchanged**
- **Integrity of existing steel coating remains unchanged**

Approval

All the loads stated in our catalog have been derived from physical testing and where you see an approval symbol, they have also been approved by that particular body. The majority of the range is **Lloyds Register Type Approved** and the **Types BA, BB, BF1, BG1, BH1** have the additional approval of the **Deutsches Institut für Bautechnik (DIBt)**



BeamClamp® Components Type BA & BB

The types **BA** and **BB** are commonly used in pairs to clamp two steel sections together. The type **BA** has a recessed top to grip the head of a grade 5 setscrew or bolt. This allows a nut and washer to be tightened down on to the flat top of the **BB** using one tool only. Both clamps are available with three tail lengths, **1, 2** or **3 (dim E)**. This should be as near to the thickness of steel it is clamping on or slightly less if an exact match is not possible. Packing pieces **BF1, BG1** and **BH1** can be used in combination with the tail length to achieve a match to the steel flange. Please see page 17 for these items. **BA** and **BB** types are suitable for parallel flanges and flanges up to 8 degrees taper. They can also be used on their own if one piece of the steelwork has been pre-drilled. To simplify the selection of tail lengths and packing pieces, please see the tables on pages 27 and 28.

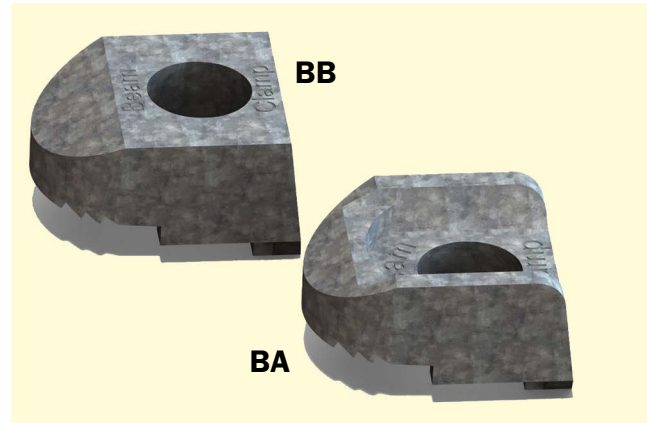

- Hot Dip Galvanized to BS EN ISO 1461
- Manufactured from Ductile Iron to BS EN 1563
- 5 to 1 Factor of Safety
- Lloyds Register approved
- DIBt approved



The Safe Working Loads are based on assemblies tested in typical conditions

Product Code	Product Code	A Bolt Dia	B	C	D1	D2	E			Width	Torque (ft lb)	Tensile SWL (lbs) (per bolt)	Friction SWL (lbs) (per 4 bolts)
							1	2	3				
BA G08	BB G08	5/16	3/8	5/8	3/16	3/8	X	1/8	X	13/16	4	281	X
BA G10	BB G10	3/8	1/2	13/16	1/4	7/16	1/8	3/16	5/16	1	14	562	X
BA G12	BB G12	1/2	5/8	1	5/16	1/2	3/16	1/4	3/8	1-1/8	51	1293	292
BA G16	BB G16	5/8	11/16	1-1/4	3/8	11/16	1/4	5/16	7/16	1-7/16	109	2219	877
BA G20	BB G20	3/4	13/16	1-3/8	7/16	13/16	5/16	3/8	1/2	1-3/4	210	3703	2473
BA G24	BB G24	1	1	1-15/16	1/2	1	3/8	1/2	5/8	2-1/8	355	4743	4047

Add 1, 2 or 3 to the product code to indicate the desired tail length. For example, a 5/8" bolt diameter with a 5/16" tail would be product code **BA2G16**.

Do not exceed the Safe Working Load (SWL) specified

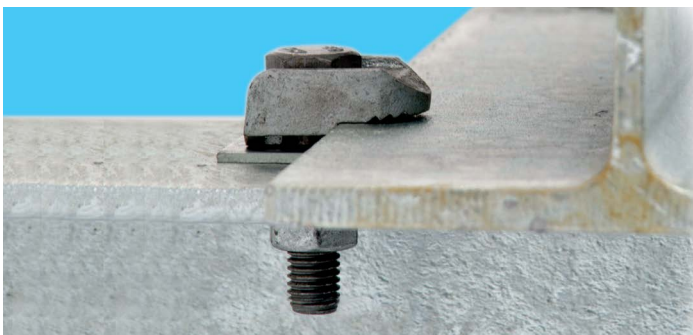
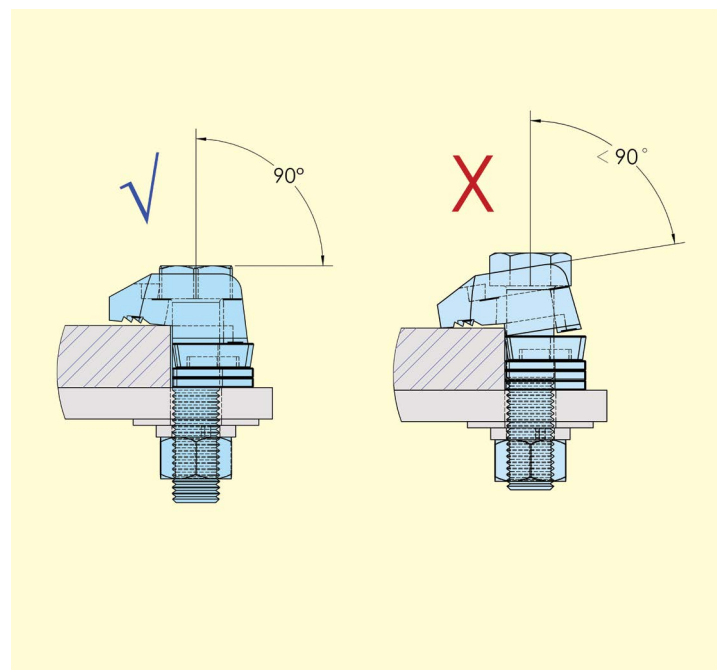
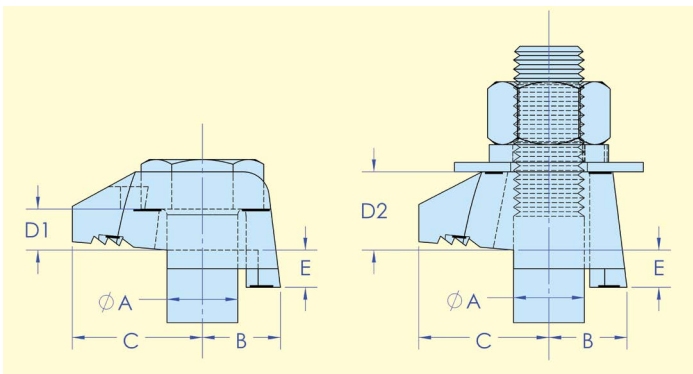

BeamClamp® Components Type BT & BW

The types **BT** and **BW** are specifically designed with a **10 degrees** sloping nose. This sloping nose makes them ideal for clamping on to tapered steel such as S beams or crane rail sections. The type **BT** has a recessed top to captivate the head of a grade 5 setscrew or bolt. The type **BW** has a flat top to allow a nut and washer to be tightened down on it. Both clamps are available with two tail lengths, **1** or **2 (dim E)**. This should be as near to the thickness of steel it is clamping to or slightly less if an exact match is not possible. Packing pieces **BF1**, **BG1** and **BH1** can be used in combination with the tail length to achieve a match to the steel flange. Please see page 17 for these items. The types **BT** and **BW** can also be used on their own if one piece of the steel has been pre-drilled. To simplify the selection of tail lengths and packing pieces, please see tables on pages 27 and 28.

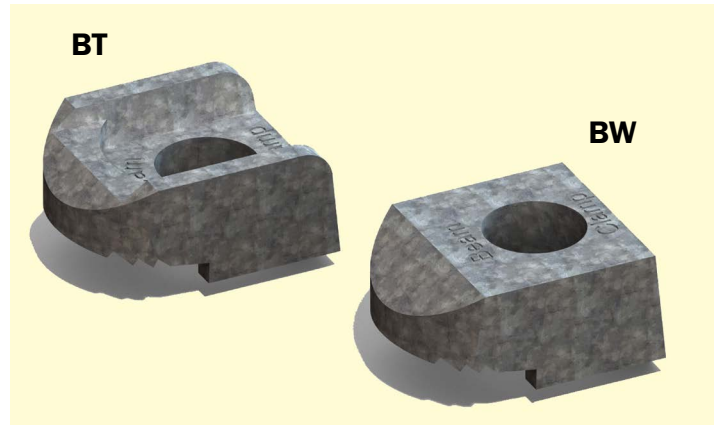

- Hot Dip Galvanized to BS EN ISO 1461
- Manufactured from Ductile Iron to BS EN 1563
- 5 to 1 Factor of Safety
- 10 degree nose

The Safe Working Loads are based on assemblies tested in typical conditions

Product Code	Product Code	A Bolt Dia	B	C	D1	D2	E		Width	Torque (ft lb)	Tensile SWL (lbs) (per bolt)	Friction SWL (lbs) (per 4 bolts)
							1	2				
BT G12	BW G12	1/2	5/8	1	5/16	1/2	3/16	1/4	1-1/8	51	1293	292
BT G16	BW G16	5/8	11/16	1-1/4	3/8	11/16	1/4	5/16	1-7/16	109	2219	877
BT G20	BW G20	3/4	13/16	1-3/8	7/16	13/16	1/4	3/8	1-3/4	210	3703	2473

Add 1 or 2 to the product code to indicate the desired tail length. For example, a 5/8" bolt diameter with a 5/16" tail would be product code BT2G16.

Do not exceed the Safe Working Load (SWL) specified

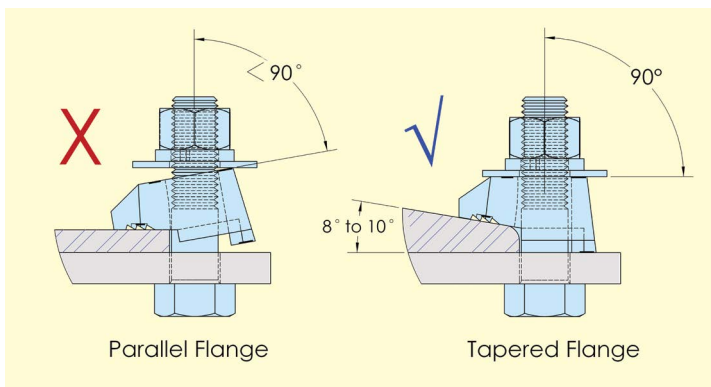
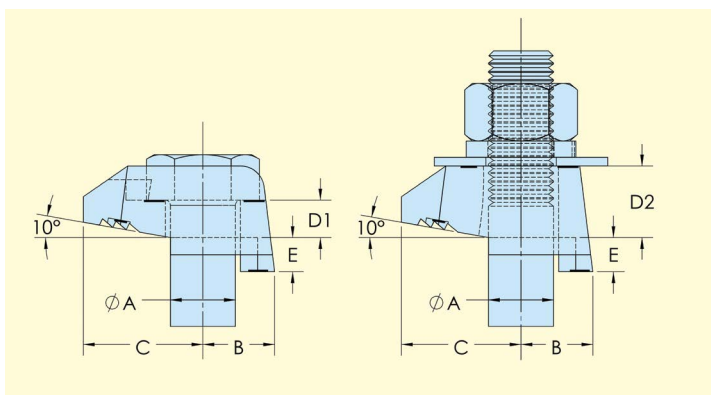

BeamClamp® Components Type BK1

The **BK1** is a self adjusting clamp that consists of two parts. The main body provides a recess to allow a hemispherical washer to be seated. This allows the body to adjust between a specified clamping range and as the washer rotates it provides a flat surface for a nut. This mechanism makes the product suitable for clamping to tapered steel of up to 15 degrees. It is also extremely useful for projects where the thickness of steel may vary. The **5/16"**, **3/8"** and **1/2"** versions feature a tab at the back edge that can be located in the open ends of strut products, both aiding installation and preventing rotation once installed. Should the maximum clamping range be exceeded, our BF2 and BG2 packers can be used to increase it. Please see page 18 for details.

The Safe Working Loads are based on assemblies tested in typical conditions.

Product Code	A Bolt Dia	B1	B2	C	D	Width	Torque (ft lb)	Tensile SWL (lbs) (per bolt)	Friction SWL (lbs) (per 4 bolts)
BK1G08	5/16	1/8 to 1/2	1/8 to 3/8	1-5/8	11/16	1-5/8	4	281	X
BK1G10	3/8	1/8 to 5/8	1/8 to 1/2	1-7/8	3/4	1-5/8	14	562	X
BK1G12	1/2	1/8 to 11/16	1/8 to 5/8	1-7/8	7/8	1-5/8	51	1,619	456
BK1G16	5/8	1/8 to 15/16	N/A	2-1/2	1-5/16	2	109	2,713	962
BK1G20	3/4	1/8 to 1-3/16	N/A	2-7/8	1-1/4	2-1/4	210	5,836	1522

Safe Working Loads are based on assemblies tested in typical conditions. Do not exceed the Safe Working Load (SWL) specified.

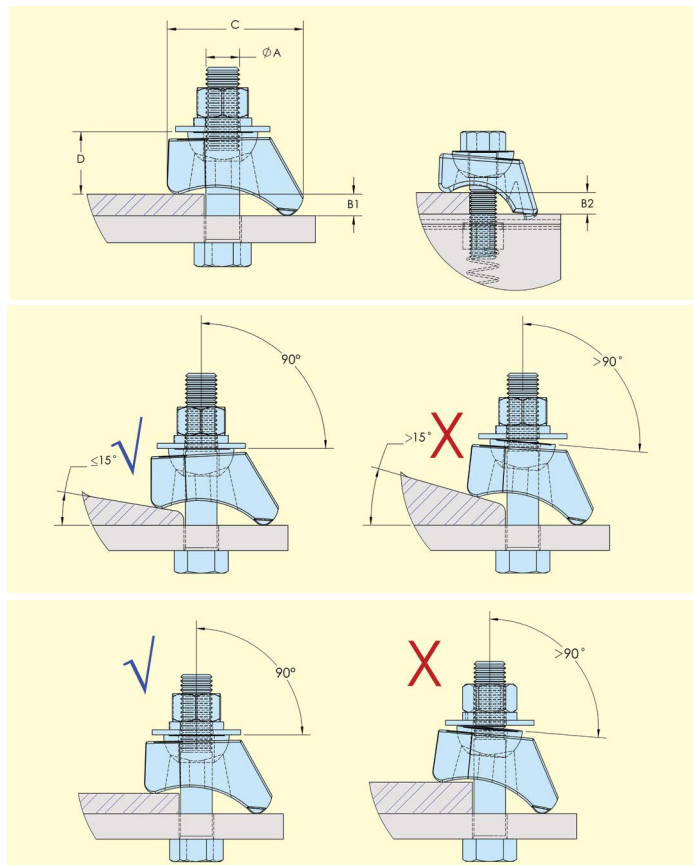

- **Hot Dip Galvanized BS EN ISO 1461**
- **Manufactured from Ductile Iron to BS EN 1563**
- **5 to 1 Factor of Safety**
- **Lloyds Register approved**
- **Self adjusting body style**



BeamClamp® Components Type BE1 & BE2

The BE1 and BE2 feature a socket screw at the back to provide adjustment for varying steel thicknesses. They are the ideal choice when flange thicknesses are unknown or change on a project. Our BF2 and BG2 packers can be used to increase the clamping range, please see page 18.

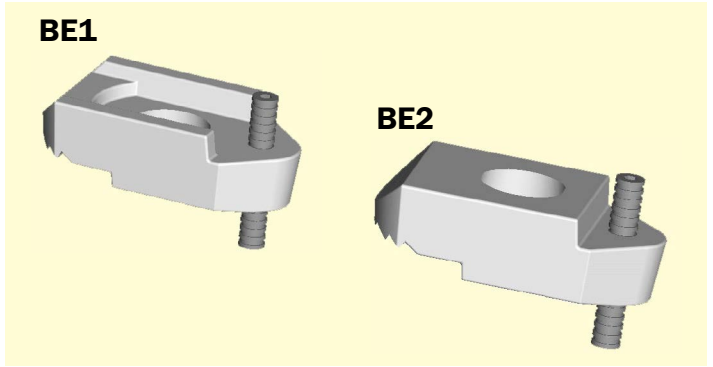
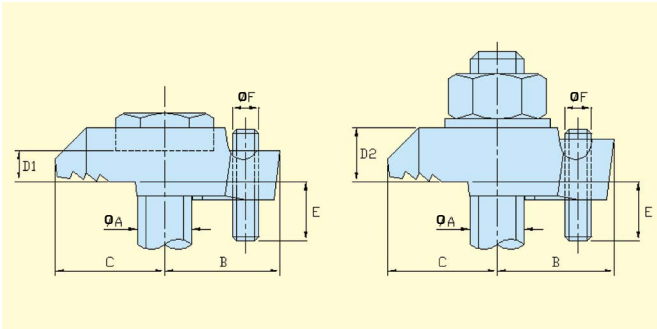

- Hot Dip Galvanized BS EN ISO 1461
- Manufactured from Ductile Iron to BS EN 1563
- 5 to 1 Factor of Safety
- LR Type Approved
- Adjustable to suit any thickness of steel



Product Code	Product Code	Bolt Dia A	B	C	D	E	Screw Dia F	Width	Torque (ft lb)	Tensile SWL (lbs) (per bolt)	Friction SWL (lbs) (per 4 bolts)
BE1G10	X	3/8	13/16	13/16	1/4	1/8 to 13/16	1/4	1	14	562	X
BE1G12	BE2G12	1/2	1	1	5/16	3/16 to 7/8	1/4	1-1/8	51	836	292
BE1G16	BE2G16	5/8	1-3/16	1-1/4	3/8	3/16 to 15/16	5/16	1-7/16	109	1855	877
BE1G20	X	3/4	1-3/8	1-3/8	7/16	3/16 to 1	3/8	1-3/4	210	3624	2473
BE1G24	X	1	1-15/16	1-15/16	1/2	1/4 to 1-3/16	1/2	2-1/8	355	4743	4047

Safe Working Loads are based on assemblies tested in typical conditions. Do not exceed the Safe Working Load (SWL) specified.

BeamClamp® Components Type BM

The BM is a one piece, self adjusting clamp. This clamp adjusts between a specified clamping range and is suitable for both parallel and tapered flanges. The BM is ideal in applications where flange thicknesses vary or are unknown as well as in seismic conditions (the 5/8" RF version of the clamp is seismically rated). Should the maximum clamping range be exceeded our BF2 and BG2 packers can be used to increase it, please see page 18 for details.

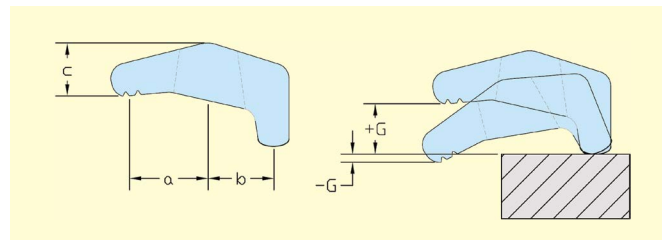

- Electro-Galvanized Tempered Steel
- 5 to 1 Factor of Safety
- Self Adjusting Body Style
- Accomodates Negative Grip Values
- RF Type Approved for Seismic Zones

Product Code	Bolt Dia	Grip Range (-G to +G)	A	B	C	Width	Torque (ft lb)	Tensile SWL (lbs) (per bolt)	Friction SWL (lbs) (per 4 bolts)
BM1G10	3/8	-1/4 - 3/8	13/16	5/8	1/2	1-1/4	44	512	410
BM1G12	1/2	-1/4 - 9/16	13/16	7/8	1/2	1-1/2	62	566	452
BM1G16	5/8	-1/4 - 11/16	1-1/4	1	11/16	1-15/16	118	1267	1012
BM1G16_RF	5/8	-1/4 - 11/16	1-13/16	1	7/8	1-15/16	43	640	X
BM1G20	3/4	-7/16 - 7/8	1-9/16	1-1/4	7/8	2-1/2	258	1608	1288

Safe Working Loads are based on assemblies tested in typical conditions. Do not exceed the Safe Working Load (SWL) specified.

BeamClamp® Components Type BC1 & BD1

The types **BC1** and **BD1** are designed to hook over the upstanding flanges of angles or channels. They can be used together for channel to channel connections or in conjunction with our other clamping products for making angle/channel connections to other types of steel. The **BC1** features a recessed top to grip a bolt head and the **BD1** has a flat top to allow a nut and washer to be tightened on to it. It is suitable for use with bolts, threaded rod or other threaded items but we always recommend the use of grade 5 or B7 high tensile threaded items.

- Hot Dip Galvanized to BS EN ISO 1461
- Manufactured from Ductile Iron to BS EN 1563
- 5 to 1 Factor of Safety
- Lloyds Register approved

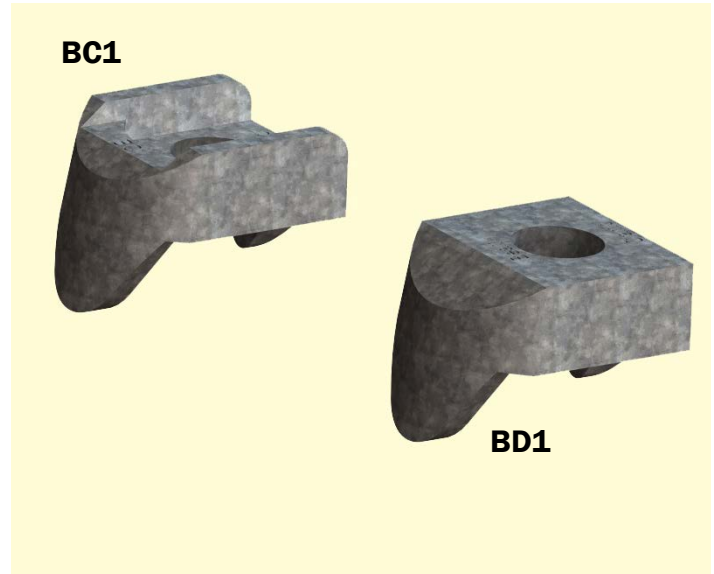

Note: These products are not recommended for frictional loads

The Safe Working Loads are based on assemblies tested in typical conditions

Product Code	Product Code	A Bolt Dia	B	C	D	E1	E2	Width	Torque (ft lb)	Tensile SWL (lbs) (per bolt)
BC1G08	BD1G08	5/16	3/8	3/16	1/4	3/16	3/8	7/8	2	281
BC1G10	BD1G10	3/8	1/2	3/16	5/16	1/4	7/16	1-3/16	7	562
BC1G12	BD1G12	1/2	5/8	1/4	3/8	5/16	1/2	1-1/4	25	971
BC1G16	BD1G16	5/8	11/16	5/16	7/16	3/8	11/16	1-5/8	54	1686
BC1G20	BD1G20	3/4	13/16	3/8	9/16	7/16	13/16	1-15/16	105	2473
BC1G24	BD1G24	1	1	1/2	11/16	1/2	1	2-3/8	178	3860

Do not exceed the Safe Working Load (SWL) specified

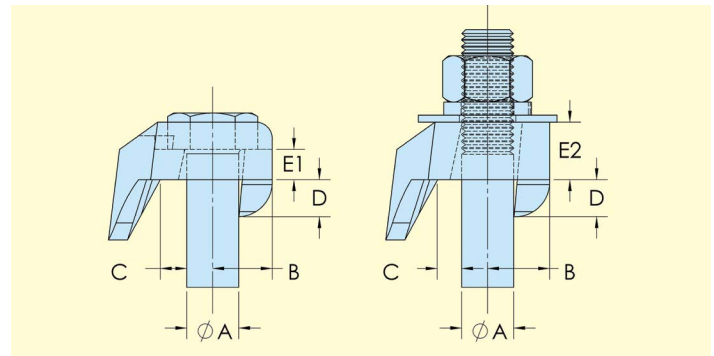
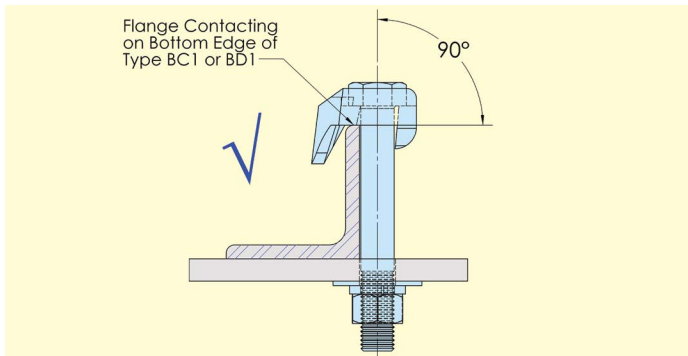

BeamClamp® Type BL Flange Clamp

The **BL** is used for clamping steel directly together without the need for a location plate. Typical applications would be clamping two steel sections of the same width running parallel or for clamping down pressure vessel lids. It can also be used with clips and brackets underneath the nut and washer side for connecting conduit or even pipe work. The clamp is tested for tensile and lateral loads, please see data sheet below. The **BL** part is specifically designed to grip the head of a bolt or nut which means the clamp can always be connected by using a single wrench. The central bolt can be replaced with other threaded items such as threaded rod, eyebolts or J-bolts to provide a suspension element.

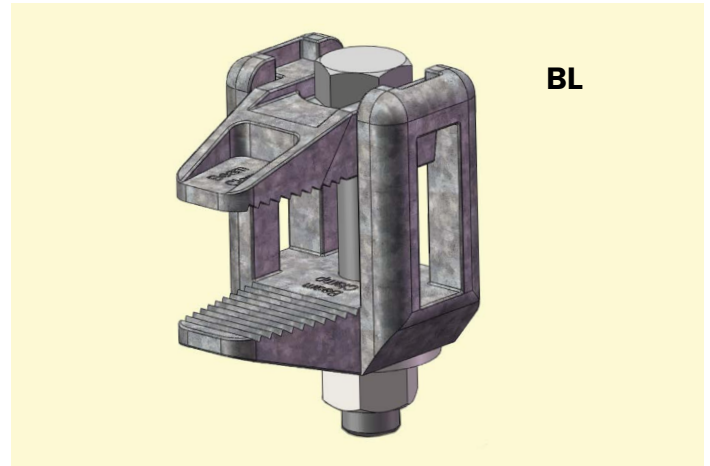

- Only requires one tool for installation
- Hot Dip Galvanized to BS EN ISO 1461
- Extensive clamping range

- Can accommodate clips/brackets
- Tested for Tensile and Lateral Loading

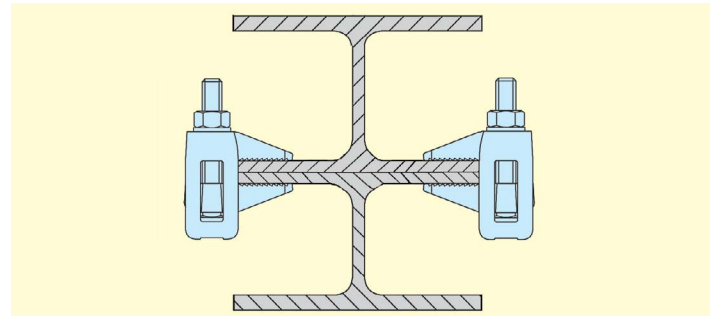
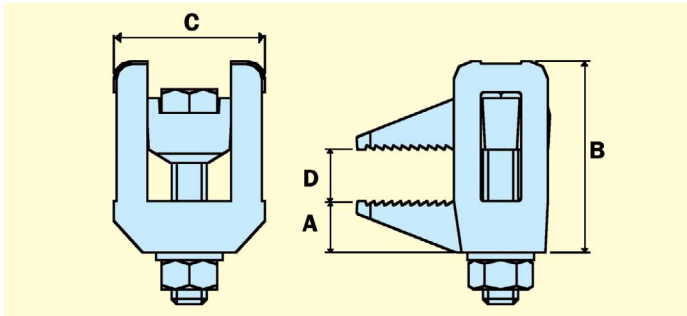

The Safe Working Loads are based on assemblies tested in typical condition.

Product Code	A	B	C	D	Tightening Torque (ft lb)	3 to 1 Factor of safety applied		
						Tensile load in line with rod (lbs)	Tensile load at nose (lbs) (per pair)	Lateral Load (lbs)
BL1G08A	1/2	1-3/4	1-9/16	0 to 13/16	7	225	1664	56
BL1G10A	9/16	2-5/16	1-7/8	0 to 1-3/16	14	562	2098	90
BL1G12A	5/8	2-9/16	2	0 to 1-3/8	29	1124	2473	135
BL1G16A	13/16	3-3/4	2-5/16	0 to 2-3/16	66	1686	4571	157
BL1G20A	7/8	4-9/16	2-5/8	0 to 2-3/4	132	2023	5246	169
BL1G24A	1	5-3/4	2-15/16	0 to 3-3/4	147	2360	7718	180

Do not exceed the Safe Working Load (SWL) specified

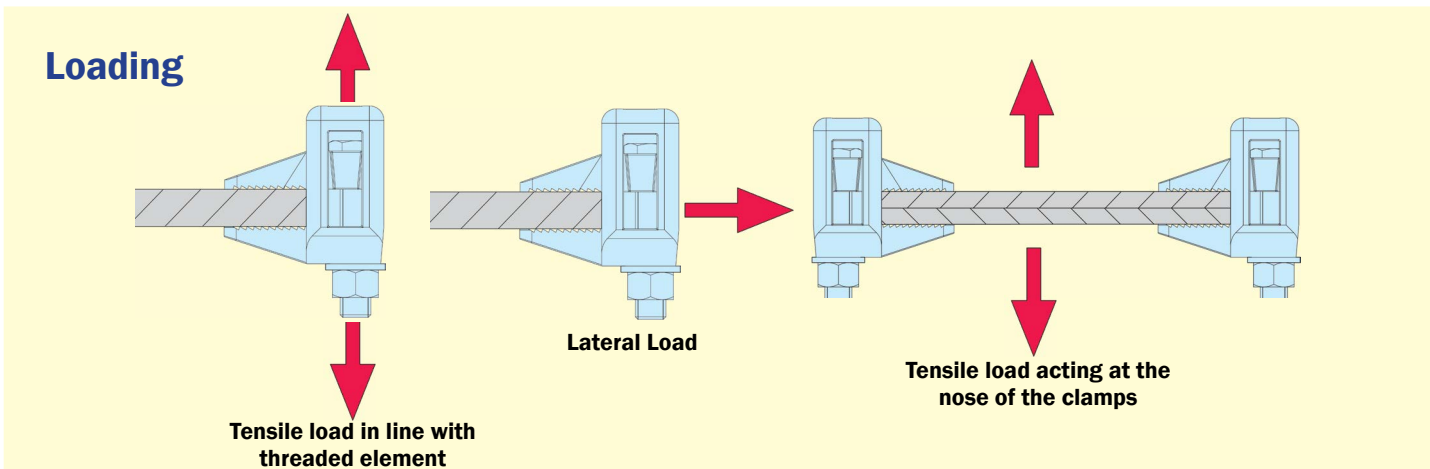

BeamClamp® Packing Pieces

Short packers for Types BA, BB, BBLN, BT and BW

BF1

Product Code	Bolt Dia.	A	B	C	D Dia.
BF1G08	5/16	1/8	9/16	7/8	3/8
BF1G10	3/8	3/16	11/16	1-1/8	7/16
BF1G12	1/2	1/4	7/8	1-3/16	9/16
BF1G16	5/8	5/16	1-1/8	1-3/8	11/16
BF1G20	3/4	3/8	1-5/16	1-11/16	13/16
BF1G24	1	1/2	1-3/4	2-3/16	1-1/16

BG1

Product Code	Bolt Dia.	A	B	C	D Dia.
BG1G08	5/16	5/16	9/16	7/8	3/8
BG1G10	3/8	3/8	11/16	1-1/8	7/16
BG1G12	1/2	1/2	7/8	1-3/16	9/16
BG1G16	5/8	5/8	1-1/8	1-3/8	11/16
BG1G20	3/4	3/4	1-5/16	1-11/16	13/16
BG1G24	1	1	1-3/4	2-3/16	1-1/16

BH1

Product Code	Bolt Dia.	A	B	C	D Dia.
BH1Z08	5/16	1/16	5/8	7/8	3/8
BH1Z10	3/8	1/16	13/16	1-1/8	7/16
BH1Z12	1/2	1/8	15/16	1-3/16	9/16
BH1Z16	5/8	1/8	1-1/8	1-3/8	11/16
BH1Z20	3/4	3/16	1-5/16	1-11/16	13/16
BH1Z24	1	3/16	1-3/4	2-3/16	1-1/16

Long packers for Type BE1, BE2, BK1 and BM

BF2

Product Code	Bolt Dia.	A	B	C	D Dia.
BF2G08	5/16	1/8	1	7/8	3/8
BF2G10	3/8	3/16	1-3/16	1-1/8	7/16
BF2G12	1/2	1/4	1-1/2	1-3/16	9/16
BF2G16	5/8	5/16	1-15/16	1-3/8	11/16
BF2G20	3/4	3/8	2-1/4	1-11/16	13/16
BF2G24	1	1/2	3	2-3/16	1-1/16

BG2

Product Code	Bolt Dia.	A	B	C	D Dia.
BG2G08	5/16	5/16	1	7/8	3/8
BG2G10	3/8	3/8	1-3/16	1-1/8	7/16
BG2G12	1/2	1/2	1-1/2	1-3/16	9/16
BG2G16	5/8	5/8	1-15/16	1-3/8	11/16
BG2G20	3/4	3/4	2-1/4	1-11/16	13/16
BG2G24	1	1	3	2-3/16	1-1/16

Our range of packing pieces is designed to provide support to the underside of clamps to ensure they clamp on to the steel at the correct angle. We have a series of short packers designed for the **BA, BB, BT** and **BW** clamps and a long series for the **BK1** clamps that reach further back on to the supporting steel. The packers can be used in combination with the clamping range of the clamp to ensure a correct connection. See tables on pages 27 and 28 for the correct combinations for different steel thicknesses.

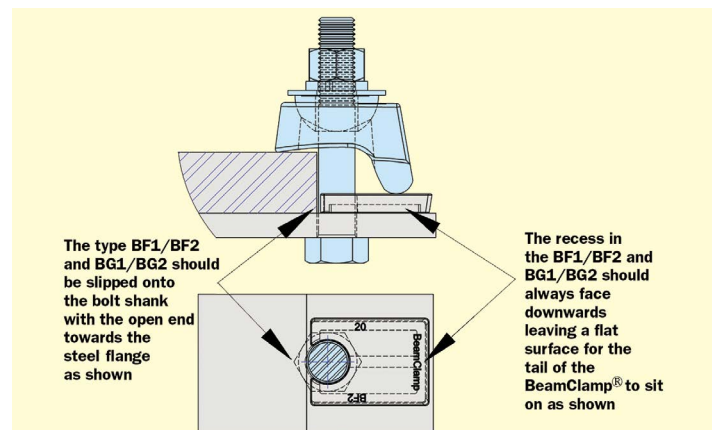
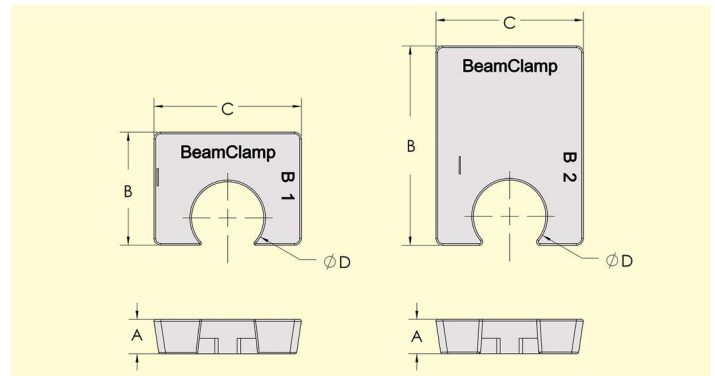
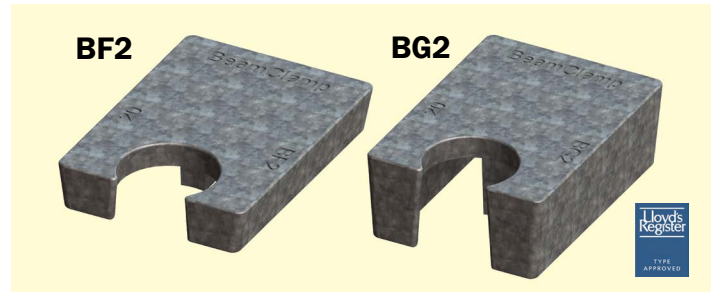
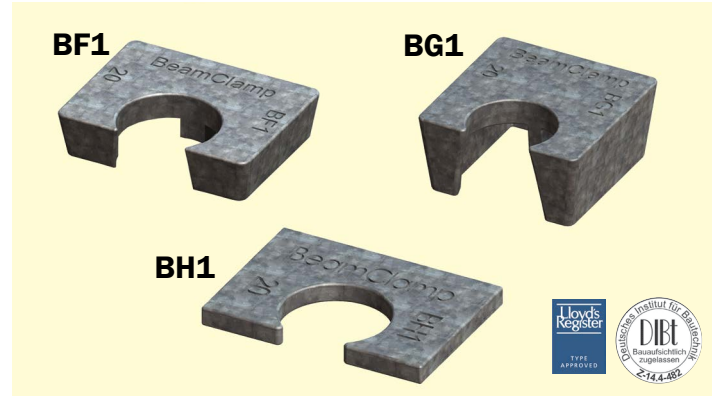

BeamClamp® Location Plates & Bolt Lengths

The location plate is an important part of a **BeamClamp** assembly. It provides support for the rear of the **BeamClamp** to react against while the front of the product clamps down on to the steel. The hole centers are designed to suit the widths of both the upper and lower members and to ensure that the clamps are located as close to the edge of the steel as possible.

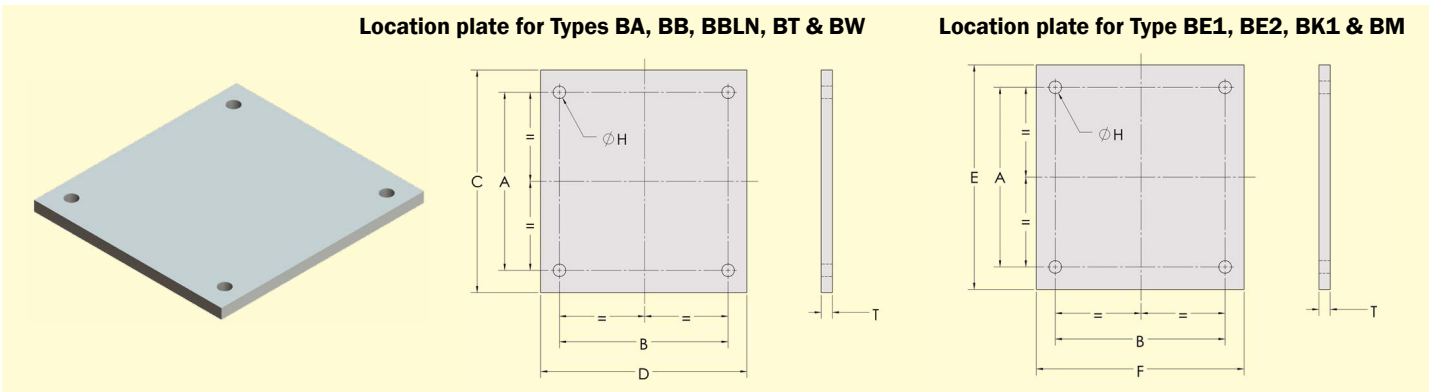

Dimension Table for BeamClamp® Location Plates

Bolt Dia	A Upper Beam Width +	B Lower Beam Width +	C Upper Beam Width +	D Lower Beam Width +	E Upper Beam Width +	F Lower Beam Width +	H Dia	T
5/16	3/8	3/8	1-1/2	1-1/2	2-1/4	2-1/4	3/8	5/16
3/8	7/16	7/16	1-3/4	1-3/4	2-5/8	2-5/8	7/16	5/16
1/2	9/16	9/16	2-1/4	2-1/4	3-3/8	3-3/8	9/16	3/8
5/8	11/16	11/16	2-3/4	2-3/4	4-1/8	4-1/8	11/16	3/8
3/4	13/16	13/16	3-1/4	3-1/4	4-7/8	4-7/8	13/16	1/2
1	1-1/8	1-1/8	4-1/2	4-1/2	6-3/4	6-3/4	1-1/8	5/8

Thickness of clamps (Dim X)

Bolt Dia	Type BA & BT (X)	Type BB & BW (X)	Type BK1 (X)
5/16	3/16	3/8	11/16
3/8	1/4	7/16	7/8
1/2	5/16	1/2	1
5/8	3/8	11/16	1-1/8
3/4	7/16	13/16	1-3/8
1	1/2	1	1-13/16

Thickness of nut/washer (Dim N)

Bolt Dia	N
5/16	7/16
3/8	1/2
1/2	5/8
5/8	13/16
3/4	15/16
1	1-1/16

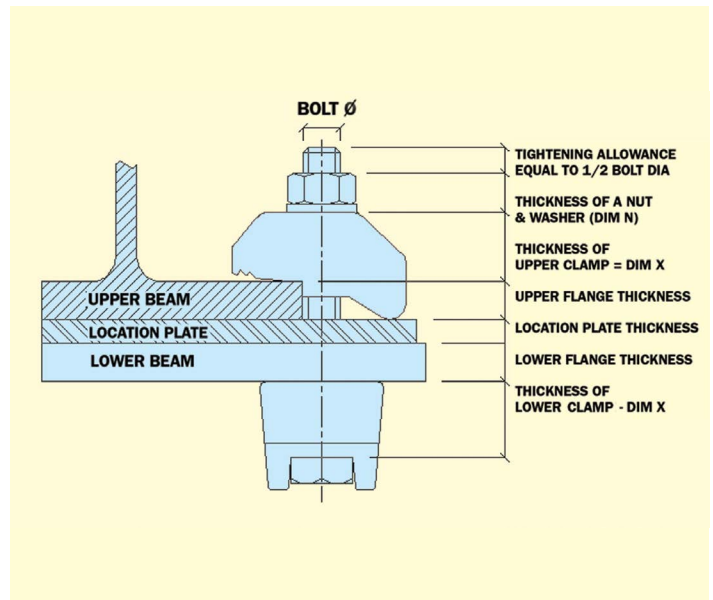
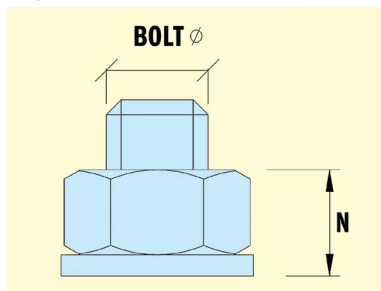

Location plates can be fabricated to suit a variety of applications with different angles of cross over and gaps between sections. We will be happy to assist, free of charge, with detailing these plates for your individual applications.

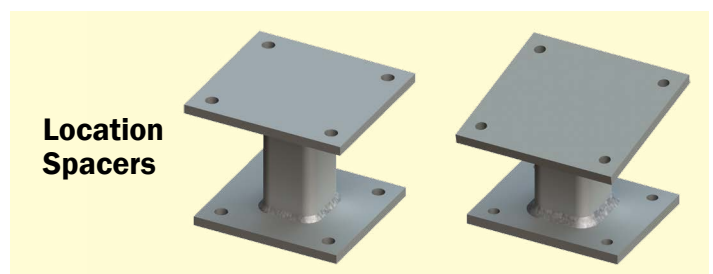

BeamClamp® High Friction Components Type BY & BYP

The Type **BY** clamp is designed for High Friction and Tensile applications that exceed the capacities of the standard BeamClamp products. It features a recessed top that prevents the head of the bolt from rotating during installation therefore requires the use of only one wrench. The Type **BYP** washer can be used to fill in the recess of the Type BY to provide a flat surface for a washer and nut. This also allows the Type BY clamps to be used together in beam to beam connections. The full width tail of the BY allows for use with slotted holes for greater diversity in applications. Please see pages 27 and 28 for beam packing combinations.

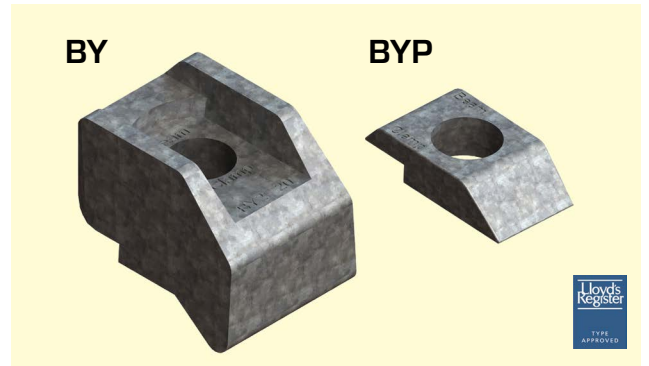

- Hot Dip Galvanized to BS EN ISO 1461
- Manufactured from Ductile Iron to BS EN 1563

These products are independently tested in situations to simulate typical site conditions.

Product Code	Bolt Grade	A Bolt Dia.	B in.	C in.	D1	D2	E		Width in.	Torque (ft lb)	Tensile SWL (lbs) per bolt (5:1 Factor of Safety)	Frictional SWL (lbs) per two bolts Painted Steel (2:1 Factor of Safety)	Frictional SWL (lbs) per two bolts Galvanized Steel (2:1 Factor of Safety)
							1	2					
BY G12	A325/Grd.5	1/2	1-1/16	1-1/8	1/2	15/16	3/16	1/2	1-9/16	66	2423	1165	3105
BY G16	A325/Grd.5	5/8	1-5/16	1-5/16	11/16	1-3/16	5/16	9/16	1-15/16	177	4145	2088	5892
BY G20	A325/Grd.5	3/4	1-9/16	1-1/2	7/8	1-7/16	3/8	11/16	2-3/16	346	7087	2974	6362
BY G12	A490	1/2	1-1/16	1-1/8	1/2	15/16	3/16	1/2	1-9/16	95	2769	2536	3876
BY G16	A490	5/8	1-5/16	1-5/16	11/16	1-3/16	5/16	9/16	1-15/16	221	4658	3606	6171
BY G20	A490	3/4	1-9/16	1-1/2	7/8	1-7/16	3/8	11/16	2-3/16	477	7524	5649	7733

Add "1" or "2" to the product code to indicate the desired tail length. For example, a 5/8" bolt diameter with 5/16" tail would be code BY1G16.

Frictional failure for the Type BY Clamp is 1mm or 0.039 inches slip from its original position.

LNA always recommends using the values for frictional loading from the painted steel column for design purposes as the thickness of galvanizing can vary between applications.

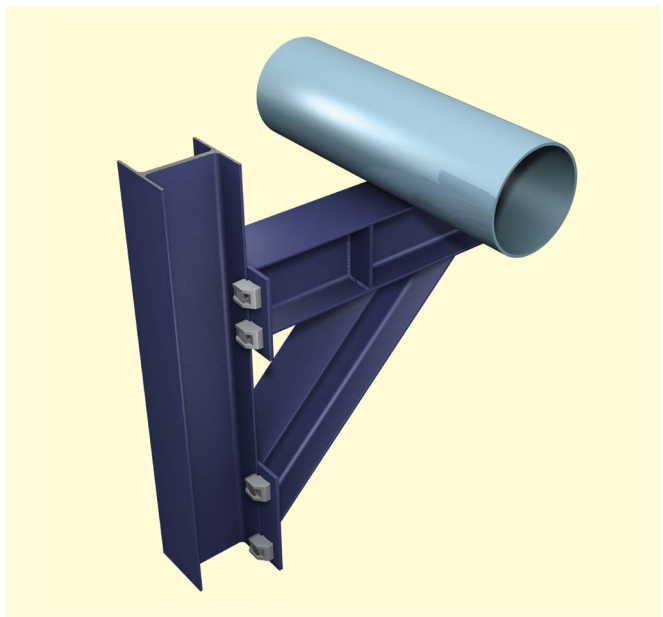
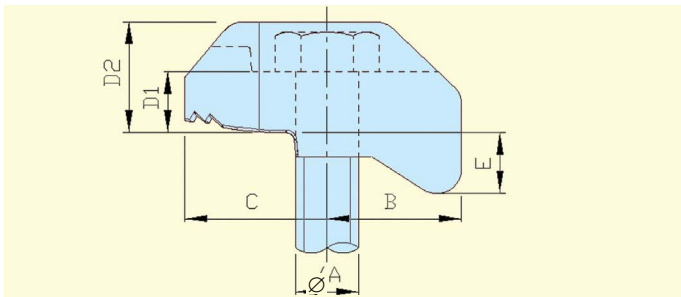

Typical end plate cantilevered connection supporting heavy duty pipe work.

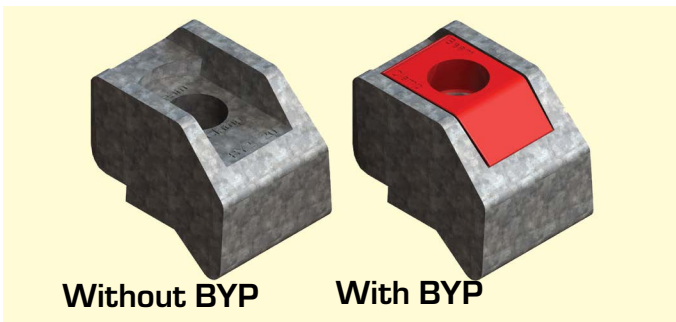

The BY recess is suitable for the hexagonal head of 1/2" Grade 5 bolts, 5/8" A325/A490 bolts and 3/4" A325/A490 bolts. The Type BYP may be used to fill in the recess allowing for any grade bolt or nut to be tightened down to its surface.



BeamClamp® Packing Pieces for BY Clamps

The range of packing pieces below are designed to provide support to the underside of type **BY** clamps to ensure they clamp at 90 degrees to the steel and provide a flat surface for the bolt head or nut to be tightened down on to. These can be used in various combinations with the two tail lengths of BY clamps to achieve the best clamping position.

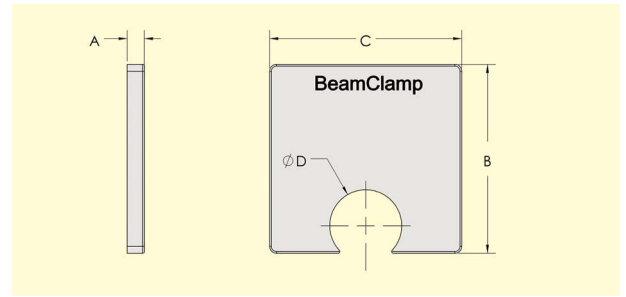

Type BF3



Type BF4

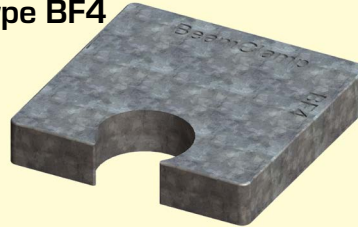

Type BH2



Product Code	A in.	B in.	C in.	Ø D in.
BF3G12	3/16	1-9/16	1-9/16	9/16
BF3G16	3/16	2	2-1/16	11/16
BF3G20	3/16	2-3/16	2-3/16	13/16

Product Code	A in.	B in.	C in.	Ø D in.
BF4G12	3/8	1-9/16	1-9/16	9/16
BF4G16	3/8	2	2-1/16	11/16
BF4G20	3/8	2-3/16	2-3/16	13/16

Product Code	A in.	B in.	C in.	Ø D in.
BH2G12	1/16	1-9/16	1-9/16	9/16
BH2G16	1/16	1-7/8	1-7/8	11/16
BH2G20	1/16	2	2	13/16

The Type BY can be used in a variety of applications and our design team will be pleased to configure a connection specific to your requirements. A cut sheet is available for manually working out of the tail length and packing piece combinations along with the bolt lengths and location plate dimensions and is available upon request.

BeamClamp® Components Type BB Long Nose (BBLN)

The **BB Long Nose** is very similar to our standard type BB but with an extended nose. This distributes more contact on the flanges of parallel beams providing, contact closer to the web. Packing pieces BH1, BF1 and BG1 can be used with this product to make it fit to various thickness's of steel at 90 degrees, see page 18 for details.

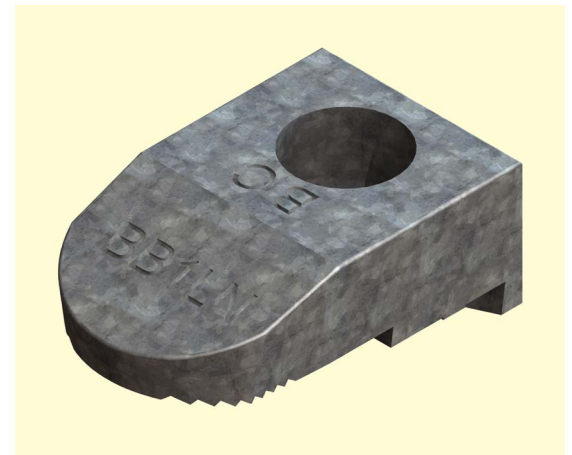
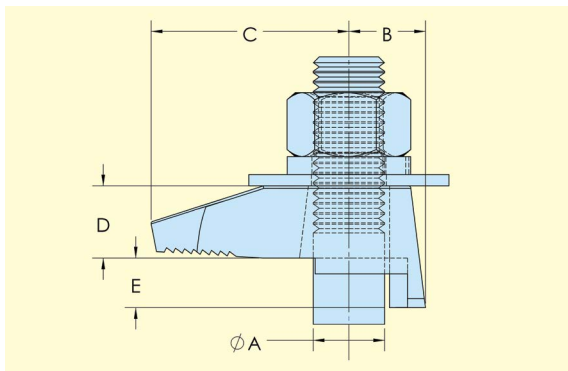

- Hot Dip Galvanized to BS EN ISO 1461
- Manufactured from Ductile Iron to BS EN 1563
- 5 to 1 Factor of Safety
- Independently tested

Product Code	Bolt Grade	A Bolt Dia.	B in.	C in.	D in.	E in.	Width in.	Torque (ft lb)	Tensile SWL (lbs) per bolt (5:1 Factor of Safety)	Frictional SWL (lbs) per four bolts Galvanized Steel (5:1 Factor of Safety)
BB1LNG12	Grd 5	1/2	9/16	1-13/16	11/16	1/4	1-1/8	51	1292	287
BB1LNG16	Grd 5	5/8	11/16	1-3/4	5/8	7/16	1-7/16	109	2218	872

BeamClamp® Location Plates & Bolt Lengths - BY

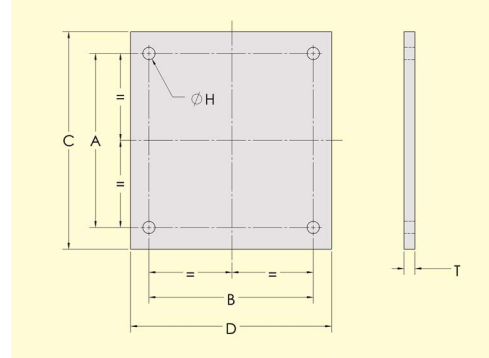
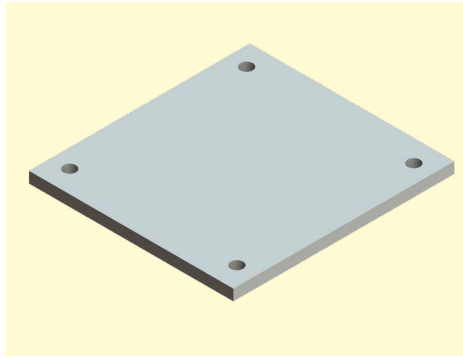

Dimension table for location plates to suit BY products

Bolt Dia.	Bolt Grade	A (in) Upper Beam width +	B (in) Lower Beam width +	C (in) Upper Beam Min. width +	D (in) Lower Beam Min. width +	H (in) Dia.	T (in) Min.
1/2	A325/Grd.5	9/16	9/16	3-3/4	3-3/4	9/16	1/2
1/2	A490	9/16	9/16	3-3/4	3-3/4	9/16	1/2
5/8	A325/Grd.5	11/16	11/16	4-5/8	4-5/8	11/16	5/8
5/8	A490	11/16	11/16	4-5/8	4-5/8	11/16	5/8
3/4	A325/Grd.5	13/16	13/16	5	5	13/16	3/4
3/4	A490	13/16	13/16	5	5	13/16	1

Note: Cap/End plate thickness will vary based on the design code followed, the flange width of the applicable beam and the type of load acting on the connection. Please contact a structural engineer for further details.

Bolt length calculation - BY BeamClamp

Thickness of clamps (Dim X)

Bolt Dia.	Type BY (X)	Type BY + BYP (X)
1/2	1/2	15/16
5/8	11/16	1-3/16
3/4	7/8	1-7/16

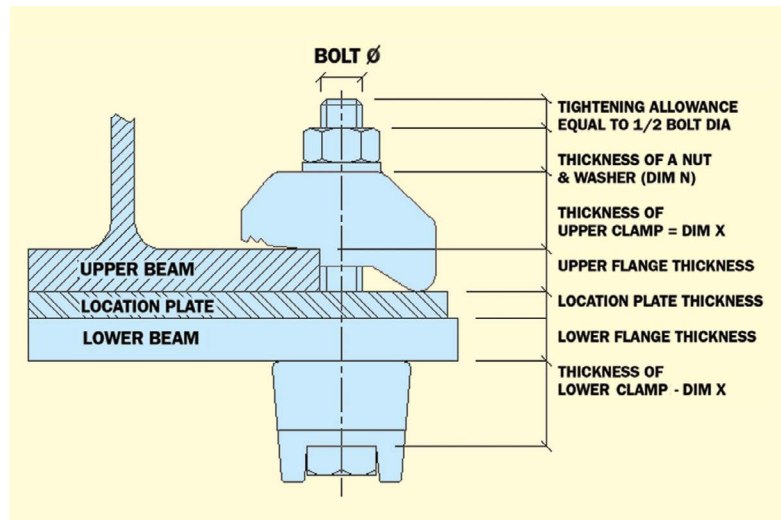

Thickness of nut & washer (Dim N)

Bolt Dia.	N
1/2	5/8
5/8	13/16
3/4	15/16

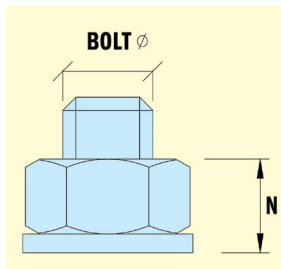

Location Spacers

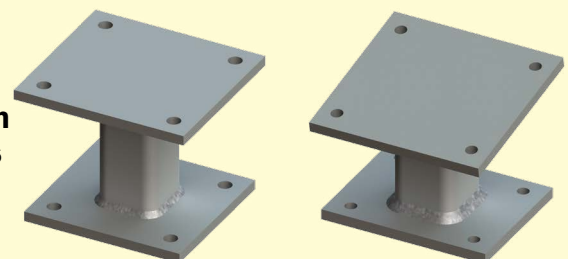

Steel Connection Solutions

Typical BeamClamp® Assembly

The diagram to the left is an example of a typical BEAMCLAMP assembly used to connect two steel sections together. The assembly consists of a pre-drilled location plate inserted between the two steel sections. An upper set of BEAMCLAMP components clamp down on the lower flange of the upper beam while a lower set of components work in the opposite direction, clamping the underside of the upper flange of the lower member. Additional packing shims may be used to adjust the clamp to the thickness of the flange being connected. The connection is secured by inserting a bolt through each of the lower clamps, the location plate, the upper clamps and then tightening a nut to the recommended torque. LNA SOLUTIONS is pleased to offer a free design service to advise on the appropriate components for your particular assembly. In addition, we are pleased to include a quotation for your supply of bolts, nuts, washers and pre-drilled location plates.

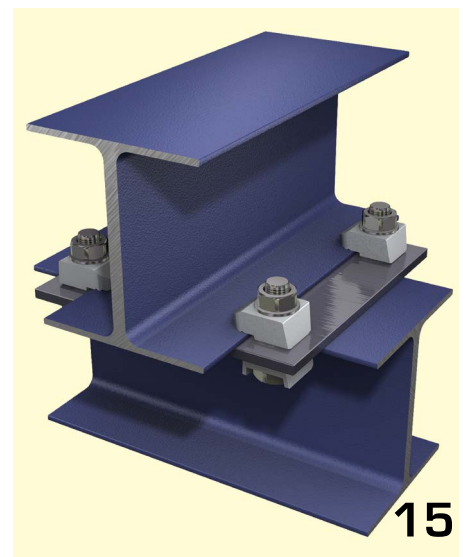
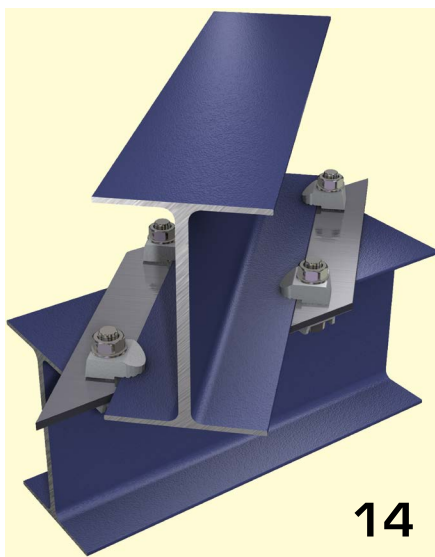
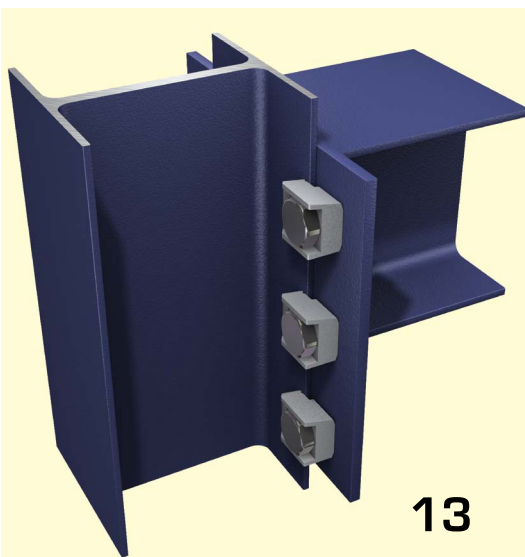
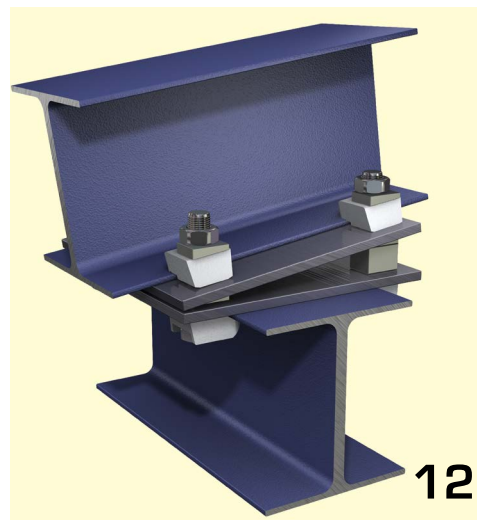
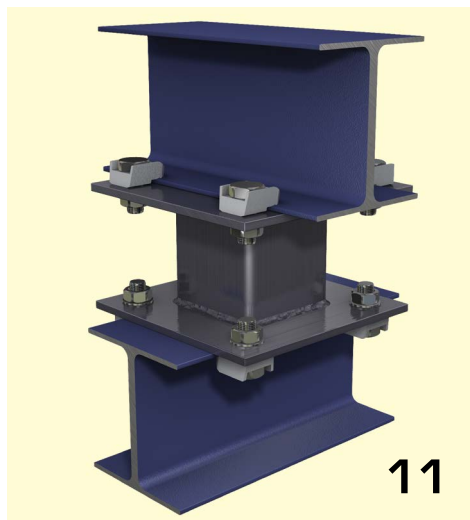
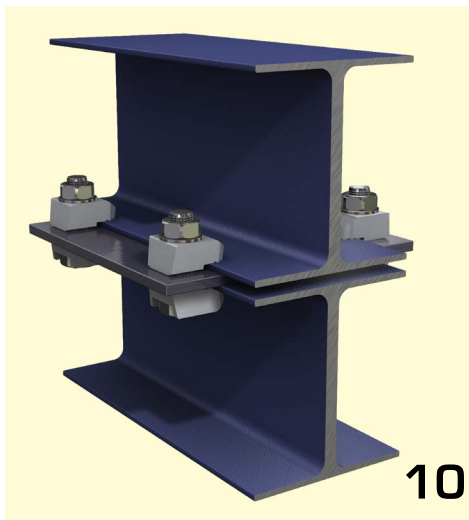
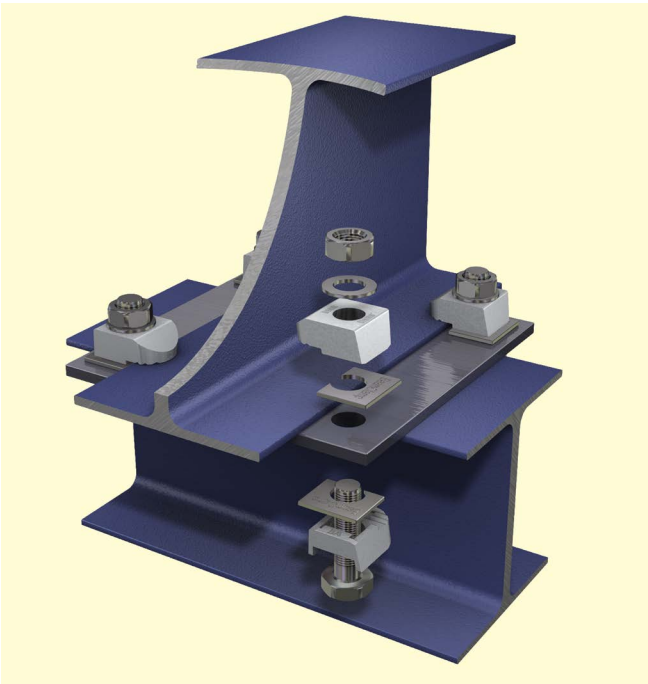

Steel Connection Solutions

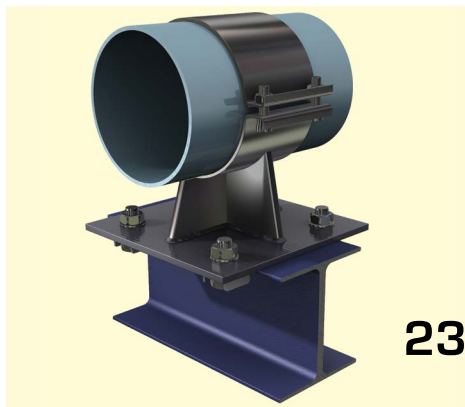
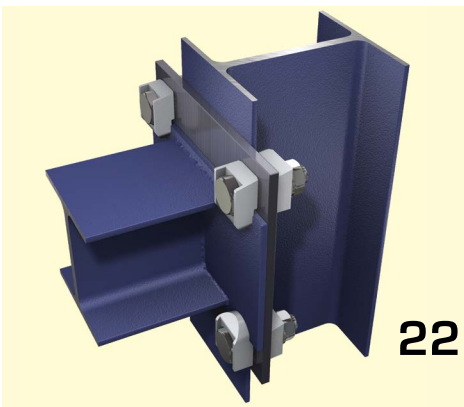
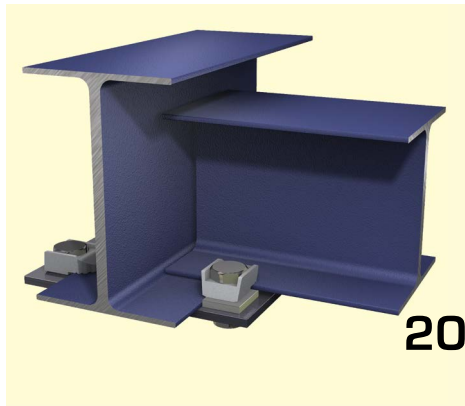
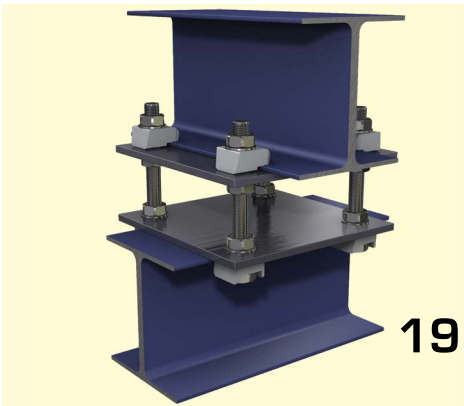
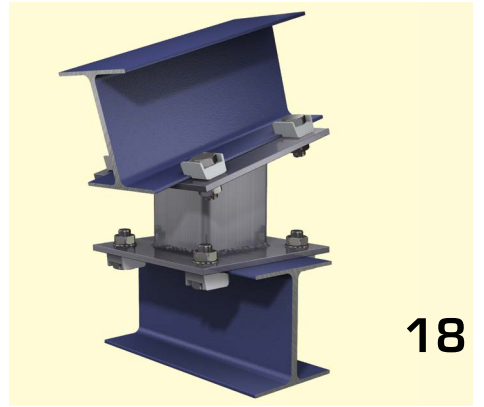
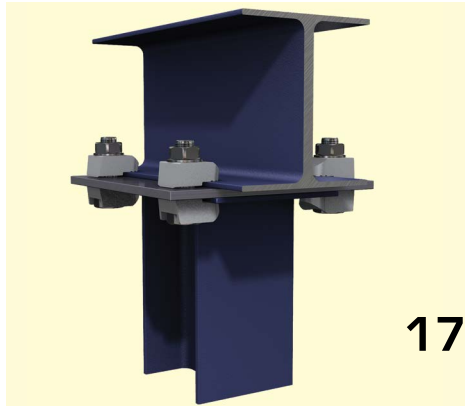
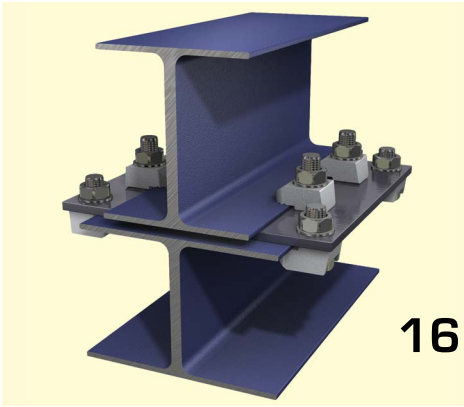

Steel Connection Solutions

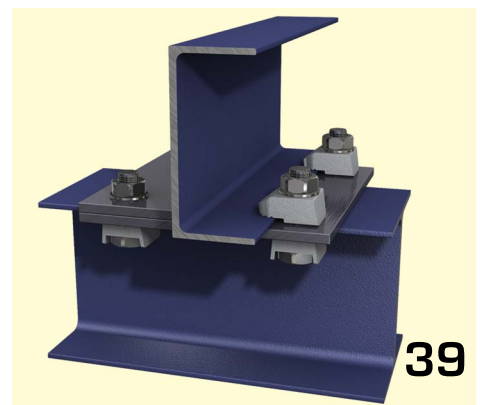
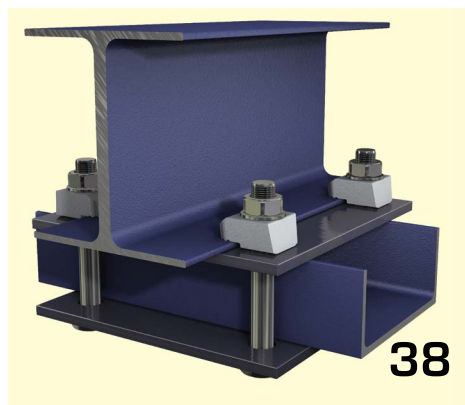
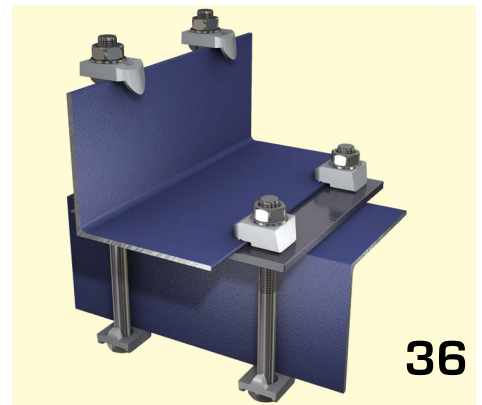
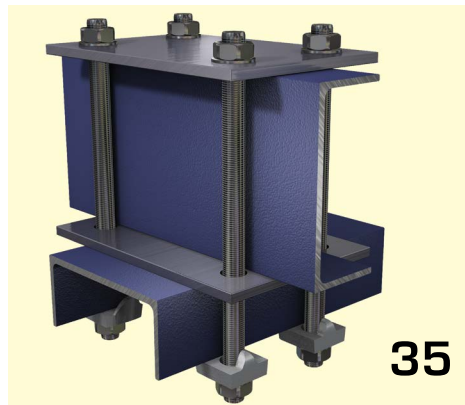
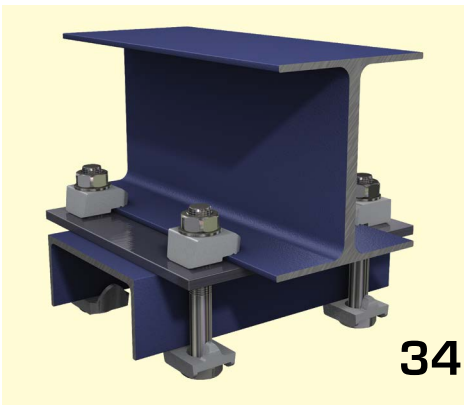
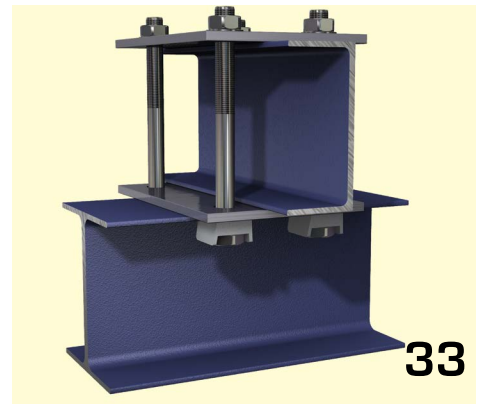
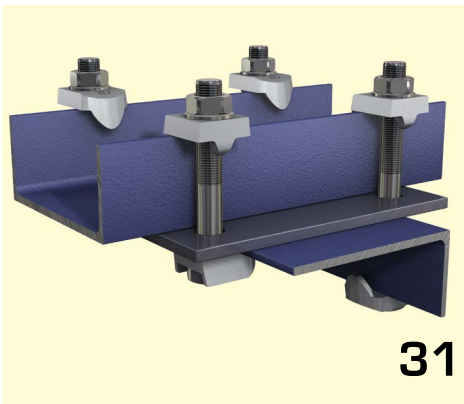
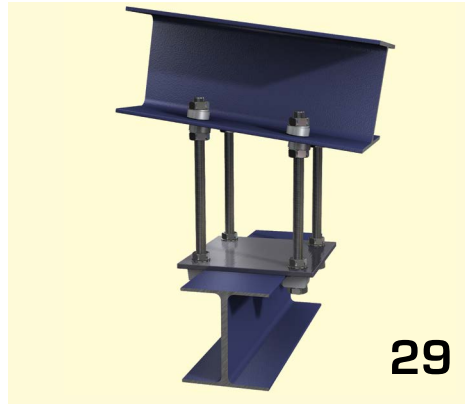

Specifying the Correct BeamClamp® Product

Specifying the Correct BeamClamp® Product

It is important to select the correct Product Type, tail length, and packing shim requirement to suit your application. Unless using an adjustable tail Type BK1 the combined tail length plus the thickness of the shim(s) must be equal to the thickness of steel being clamped.

The following tables are designed to assist you in selecting the appropriate combination.

For Wide Flange Beams and Parallel Steel - Table 1

For Structural I-Beams - Table 2

For C-Channels - Table 3

Tables are located on pages 27 and 28

The following steps will help in using these tables correctly:

- 1) Select the type of clamp you wish to use: BA, BB, BT, BW, BK1 or BY.
- 2) Select the bolt size you wish to use. The load capacity for each product is stated on the individual product pages. LNA SOLUTIONS recommends that SAE Grade 5 Bolts are used.
- 3) When connecting to wide flange beams or parallel flanges, refer to steel guides to find the flange thickness.
- 4) Using the Tables 1, 2, or 3, select the appropriate tail length and packing.

Table 1: Example For Wide Flange and Parallel Steel:

If you wish to use a 3/8" diameter Type BB Clamp to secure a W10 x 45 wide flange beam, you would

- 1) Referring to steel guides, look up the thickness of the flange. For a W10 x 45 the thickness is 5/8".
- 2) Read down the 3/8" BA & BB Column and read across the 5/8" thickness row until they intersect.
- 3) The correct tail length is a Size 2 complete with a Type BG1 Packing.

Flange Thickness	5/16" Bolt dia		3/8" Bolt dia	
	BA & BB	BK1	BA & BB	BK1
1/8	X	OK	X	OK
3/16	2	OK	2	OK
1/4	2 + BH1	OK	1 + BH1	OK
5/16	2 + BF1	OK	3	OK
3/8	2 + BH1 + BF1	OK	1 + BF1	OK
7/16	2 + BH1 + BF1	OK	3 + [2 x BH1]	OK
1/2	2 + BG1	+ BF2	3 + [3 x BH1]	OK
9/16	2 + BH1 + BG1	+ BF2	1 + BG1	OK
5/8	2 + BF1 + BG1	+ BF2	1 + BH1 + BG1	+ BF2
11/16	2 + BH1 + BF1 + BG1	+ BG2	3 + BG1	+ BF2
3/4	2 + BH1 + BF1 + BG1	+ BG2	1 + BF1 + BG1	+ BF2
13/16	2 + [2 x BG1]	+ BF2 + BG2	2 + BF1 + BG1	+ BG2
7/8	2 + BH1 + [2 x BG1]	+ BF2 + BG2	3 + BF1 + BG1	+ BG2
15/16	2 + BF1 + [2 x BG1]	+ BF2 + BG2	1 + [2 x BG1]	+ BG2
1	2 + BF1 + [2 x BG1]	+ [2 x BG2]	2 + [2 x BG1]	+ BG2

Table 2: Example For Structural I-Beams and

If you wish to use a 1/2" diameter Type BT Clamp to secure an S12 x 50, you would:

- 1) Read down the 1/2" Type BT & BW column and read across the S12 x 50 row until they intersect.
- 2) The correct tail length is a Size 2 complete with two Type BH1 Packings.

S-beam size	1/2" Bolt dia BT & BW	5/8" Bolt dia BT & BW
S18 x 70	2 + [2 x BH1]	2 + BH1
S18 x 54.7	2 + [2 x BH1]	2 + BH1
S15 x 50	1 + BF1	1 + BH1
S15 x 42.9	1 + BF1	1 + BH1
S12 x 50	2 + [2 x BH1]	2 + BH1
S12 x 40.8	2 + [2 x BH1]	2 + BH1
S12 x 35	2 + BH1	2
S12 x 31.8	2 + BH1	2

Key

- 1 = Short Tail Type BA, BB, BT, BW or BY
- 2 = Medium Tail BA, BB, BT, BW or BY
- 3 = Long Tail BA or BB
- BF1 = Type BF1 packing must be used
- BG1 = Type BG1 packing must be used
- BH1 = Type BH1 packing must be used
- BF2 = Type BF2 packing must be used
- BG2 = Type BG2 packing must be used
- BH2 = Type BH2 packing must be used
- BF3 = Type BF3 packing must be used
- BF4 = Type BF4 packing must be used
- OK = Product is suitable without any additional packings
- X = Not recommended

Notes:

A plus sign (+) between any of the above designations means that there is a packing required in addition to the clamp. Combinations of BH1, BF1, BG1, BF2, BG2, BH2, BF3 and BF4 packings are used.

Where "2 x" or "3 x" is indicated, use 2 or 3 as the multiplier to get the number of packings needed to suit the given flange thickness.



Table 1 - To Suit Wide Flange Beams

Flange Thickness	5/16" Bolt dia		3/8" Bolt dia		1/2" Bolt dia		
	BA & BB	BK1	BA & BB	BK1	BA & BB	BK1	BY
1/8	X	OK	X	OK	X	OK	X
3/16	2	OK	2	OK	1	OK	1
1/4	2 + BH1	OK	1 + BH1	OK	2	OK	1
5/16	2 + BF1	OK	3	OK	2 + BH1	OK	1 + BH2
3/8	2 + BH1 + BF1	OK	1 + BF1	OK	3	OK	1 + BF3
7/16	2 + BH1 + BF1	OK	3 + [2 x BH1]	OK	2 + [2 x BH1]	OK	1 + BF3
1/2	2 + BG1	+ BF2	3 + [3 x BH1]	OK	1 + BH1 + BF1	OK	2
9/16	2 + BH1 + BG1	+ BF2	1 + BG1	OK	3 + [2 x BH1]	OK	2 + BH2
5/8	2 + BF1 + BG1	+ BF2	1 + BH1 + BG1	+ BF2	3 + BF1	OK	1 + BF4
11/16	2 + BH1 + BF1 + BG1	+ BG2	3 + BG1	+ BF2	2 + [2 x BH1] + BF1	OK	2 + BF3
3/4	2 + BH1 + BF1 + BG1	+ BG2	1 + BF1 + BG1	+ BF2	1 + BH1 + BG1	+ BF2	1 + [2 x BH] + BF4
13/16	2 + [2 x BG1]	+ BF2 + BG2	2 + BF1 + BG1	+ BG2	2 + BH1 + BG1	+ BF2	2 + BH2 + BF3
7/8	2 + BH1 + [2 x BG1]	+ BF2 + BG2	3 + BF1 + BG1	+ BG2	1 + BF1 + BG1	+ BF2	2 + BF4
15/16	2 + BF1 + [2 x BG1]	+ BF2 + BG2	1 + [2 x BG1]	+ BG2	2 + BF1 + BG1	+ BF2	2 + BH2 + BF4
1	2 + BF1 + [2 x BG1]	+ [2 x BG2]	2 + [2 x BG1]	+ BG2	1 + BH1 + BG1 + BF1	+ BG2	1 + [2 x BF4]
1-1/16	2 + BH1 + BF1 + [2 x BG1]	+ [2 x BG2]	3 + [2 x BG1]	+ BF2 + BG2	2 + BH1 + BG1 + BF1	+ BG2	1 + BH2 + [2 x BF4]
1-1/8	2 + [3 x BG1]	+ BF2 + [2 x BG2]	1 + BF1 + [2 x BG1]	+ BF2 + BG2	1 + [2 x BG1]	+ BG2	2 + [3 x BH2] + BF4
1-3/16	2 + BH1 + [3 x BG1]	+ BF2 + [2 x BG2]	2 + BF1 + [2 x BG1]	+ BF2 + BG2	2 + [2 x BG1]	+ BG2	1 + BF3 + [2 x BF4]
1-1/4	X	X	X	X	1 + BH1 + [2 x BG1]	+ BF2 + BG2	1 + BH3 + BF3 + [2 x BF4]
1-5/16	X	X	X	X	3 + [2 x BG1]	+ BF2 + BG2	2 + [2 x BF4]
1-3/8	X	X	X	X	1 + BF1 + [2 x BG1]	+ BF2 + BG2	1 + [3 x BF4]
1-7/16	X	X	X	X	2 + BF1 + [2 x BG1]	+ [2 x BG2]	2 + [2 x BH2] + [2 x BF4]
1-1/2	X	X	X	X	X	+ [2 x BG2]	2 + BF3 + [2 x BF4]

Flange Thickness	5/8" Bolt dia			3/4" Bolt dia			1" Bolt dia	
	BA & BB	BK1	BY	BA & BB	BK1	BY	BA & BB	BK1
1/8	X	OK	X	X	OK	X	X	OK
3/16	X	OK	X	X	OK	X	X	OK
1/4	1	OK	X	1	OK	X	X	OK
5/16	2	OK	1	1	OK	X	1	OK
3/8	1 + BH1	OK	1 + BH2	2	OK	1	1	OK
7/16	3	OK	1 + BH2	1 + BH1	OK	1	2	OK
1/2	1 + [2 x BH1]	OK	1 + BF3	3	OK	1 + BH2	2	OK
9/16	3 + BH1	OK	2	2 + BH1	OK	1 + [2 x BH2]	1 + BH1	OK
5/8	2 + BF1	OK	2	3 + BH1	OK	1 + BF3	3	OK
11/16	3 + [2 x BH1]	OK	2 + BH2	1 + BF1	OK	2	1 + [2 x BH1]	OK
3/4	3 + BF1	OK	2 + [2 x BH2]	1 + [3 x BH1]	OK	2	3 + BH1	OK
13/16	3 + [3 x BH1]	OK	2 + BF3	2 + BF1	OK	2 + BH2	3 + BH1	OK
7/8	2 + [2 x BH1] + BF1	OK	2 + BH2 + BF3	2 + [3 x BH1]	OK	2 + [2 x BH2]	1 + BF1	OK
15/16	2 + BG1	OK	2 + [2 x BH2] + BF3	2 + BH1 + BF1	OK	2 + BF3	2 + BF1	OK
1	3 + [2 x BH1] + BF1	+ BF2	2 + BF4	1 + [2 x BH1] + BF1	OK	2 + BH2 + BF3	1 + BH1 + BF1	OK
1-1/16	3 + BG1	+ BF2	2 + BH2 + BF4	1 + BG1	OK	2 + 2BH2 + BF3	3 + BF1	OK
1-1/8	1 + [2 x BH1] + BG1	+ BF2	1 + [2 x BF4]	2 + [2 x BH1] + BF1	OK	2 + BF4	3 + BF1	OK
1-3/16	3 + BH1 + BG1	+ BF2	2 + BF3 + BF4	2 + BG1	OK	2 + BH2 + BF4	1 + [2 x BH1] + BF1	OK
1-1/4	2 + BF1 + BG1	+ BF2	2 + BH2 + BF3 + BF4	1 + BH1 + BG1	+ BF2	2 + [2 x BH2] + BF4	3 + BH1 + BF1	OK
1-5/16	2 + BF1 + BG1	+ BG2	1 + BF3 + [2 x BF4]	2 + BH1 + BG1	+ BF2	2 + BF3 + BF4	1 + BG1	OK
1-3/8	3 + BF1 + BG1	+ BG2	2 + [2 x BF4]	2 + BH1 + BG1	+ BF2	2 + BH2 + BF3 + BF4	1 + BG1	OK
1-7/16	3 + BF1 + BG1	+ BG2	2 + [2 x BH2] + [2 x BF4]	3 + BH1 + BG1	+ BF2	2 + [2 x BH2] + BF3 + BF4	2 + BG1	+ BF2
1-1/2	3 + BH1 + BF1 + BG1	+ BG2	1 + [3 x BF4]	2 + [2 x BH1] + BG1	+ BF2	2 + [2 x BF4]	1 + BH1 + BG1	+ BF2

Table 2 - To Suit S-Beams

S-beam size	1/2" Bolt dia BT & BW	5/8" Bolt dia BT & BW	3/4" Bolt dia BT & BW	1/2" Bolt dia BY	5/8" Bolt dia BY	3/4" Bolt dia BY
S24 x 121	1 + BH1 + BG1	2 + BH1 + BF1	1 + [3 x BH1]	2 + BH2 + BF3	2 + BF3	2 + BH2
S24 x 106	1 + BH1 + BG1	2 + BH1 + BF1	1 + [3 x BH1]	2 + BH2 + BF3	2 + BF3	2 + BH2
S24 x 100	2 + BH1 + BF1	1 + BF1	1 + [2 x BH1]	2 + BH2	2	1 + BF3
S24 x 90	2 + BH1 + BF1	1 + BF1	1 + [2 x BH1]	2 + BH2	2	1 + BF3
S24 x 80	2 + BH1 + BF1	1 + BF1	1 + [2 x BH1]	2 + BH2	2	1 + BF3
S20 x 96	1 + BG1	1 + [3 x BH1]	1 + [2 x BH1]	1 + BF4	2	1 + BF3
S20 x 86	1 + BG1	1 + [3 x BH1]	1 + [2 x BH1]	1 + BF4	2	1 + BF3
S20 x 75	2 + [3 x BH1]	1 + BF1	2 + BH1	2 + BH2	1 + BF3	1 + [2 x BH2]
S20 x 66	2 + [3 x BH1]	1 + BF1	2 + BH1	2 + BH2	1 + BF3	1 + [2 x BH2]
S18 x 70	2 + [2 x BH1]	2 + BH1	1 + BH1	1 + BF3	1 + BH2	1
S18 x 54.7	2 + [2 x BH1]	2 + BH1	1 + BH1	2	1 + [2 x BH2]	1 + BH2
S15 x 50	1 + BF1	1 + BH1	2	1 + BF3	1 + BH2	1
S15 x 42.9	1 + BF1	1 + BH1	2	1 + BF3	1 + BH2	1
S12 x 50	2 + [2 x BH1]	2 + BH1	1 + BH1	1 + [3 x BH2]	1 + BH2	1
S12 x 40.8	2 + [2 x BH1]	2 + BH1	1 + BH1	1 + [3 x BH2]	1 + [2 x BH2]	1 + BH2
S12 x 35	2 + BH1	2	1	1 + [2 x BH2]	1	1
S12 x 31.8	2 + BH1	2	1	1 + [2 x BH2]	1	1
S10 x 35	1 + BH1	2	1	1 + BH2	1	X
S10 x 25.4	1 + BH1	2	1	1 + BH2	1	X
S8 x 23	2	1	1	1 + BH2	1	X
S8 x 18.4	2	1	1	1 + BH2	1	X
S7 x 20	2	1	1	1 + BH2	X	X
S7 x 15.3	2	1	1	1 + BH2	X	X
S6 x 17.25	1	1	X	1	X	X
S6 x 12.5	2	1	X	1	X	X
S5 x 14.75	1	1	X	1	X	X
S5 x 10	1	1	X	1	X	X
S4 x 9.5	1	X	X	1	X	X
S4 x 7.7	1	X	X	1	X	X
S3 x 7.5	1	X	X	1	X	X
S3 x 5.7	1	X	X	1	X	X

Table 3 - To Suit C-Channels

Channel Size	1/2" Bolt dia BT & BW	5/8" Bolt dia BT & BW	3/4" Bolt dia BT & BW	1/2" Bolt dia BY	5/8" Bolt dia BY	3/4" Bolt dia BY
C15 x 50	1 + [2 x BH1]	1 + BH1	2	1 + BF3	1 + BH2	1
C15 x 40	1 + [2 x BH1]	1 + BH1	2	1 + BF3	1 + BH2	1
C15 x 33.9	1 + [2 x BH1]	1 + BH1	2	1 + BF3	1 + BF3	1
C12 x 30	2	1	1	1 + BH2	1	X
C12 x 25	2	1	1	1 + BH2	1	X
C12 x 20.7	2	1	1	1 + BH2	1	X
C10 x 30	2	1	1	1	X	X
C10 x 25	2	1	1	1	X	X
C10 x 20	2	1	1	1	X	X
C10 x 15.3	2	1	1	1	X	X
C9 x 20	2	1	1	1	X	X
C9 x 15	2	1	1	1	X	X
C9 x 13.4	2	1	1	1	X	X
C8 x 18.75	2	1	1	1	X	X
C8 x 13.75	2	1	1	1	X	X
C8 x 11.5	2	1	1	1	X	X
C7 x 14.75	1	1	X	1	X	X
C7 x 12.25	1	1	X	1	X	X
C7 x 9.8	1	1	X	1	X	X
C6 x 13	1	1	X	1	X	X
C6 x 10.5	1	1	X	1	X	X
C6 x 8.2	1	1	X	1	X	X
C5 x 9	1	1	X	1	X	X
C5 x 6.7	1	1	X	1	X	X
C4 x 7.25	1	X	X	1	X	X
C4 x 5.4	1	X	X	1	X	X
C3 x 6	1	X	X	1	X	X
C3 x 5	1	X	X	1	X	X
C3 x 4.1	1	X	X	1	X	X



BeamClamp® Connection Designer in 3 easy steps



Connection Designer
at www.LNASolutions.com

The engineering staff at LNA Solutions specialize in structural steel connections. They will quickly and efficiently take your connection information and create assembly specific drawings to suit your project specifications. A full flange bending analysis is available upon request as well as PE sign-offs. This service can save you valuable billing hours and best of all it is free.

- **AutoCAD or SolidWorks Output**
- **Full Flange Bending Analysis**
- **PE sign off available**
- **Fast & Friendly Replies**
- **Free service with no obligation**
- **24 hour or less response**
- **Terrific Service & Support**
- **Expert design team**

Quick Reference

The following will be the information that we need to design your structural steel connection.

LOAD PER CONNECTION:

Tensile _____ lbs

Frictional _____ lbs

ANGLE CROSSOVER SECTION:

Perpendicular

Parallel

Skewed Angle Degree of angle _____

PLEASE STATE ANY SPECIAL CONDITIONS: (vibration, etc)

Inclined Beams

If yes, please describe: _____

Elevation Drop: _____ inches

Other: _____

Corrosion protection of beams _____

Number of connections required _____

Beam	Beam Designation	Flange Width	Flange Thickness
Top			
Bottom			

Does your connection resemble any of the connections seen on pages 23-25? _____

ITEM NO.	BeamClamp PART#	QTY.
1	BA2G16	4
2	B81G16	4
3	BH1Z16	4
4	3/8" Location Plate	1
5	5/8" x 3-1/4" Grd. 5 Bolt Set	4

BeamClamp
 SAFE WORKING TENSION LOAD = 8,876 lbs
 FACTOR OF SAFETY ON BEAMCLAMP CLAMPS = 5:1
 BOLT TORQUE = 109 ft lbs

CUSTOMER: Ann Arbor IronWorks
 DATE: 2/4/11
 DRAWN BY: JJS
 SCALE: N-T-S

When designing a connection using our clamps, it is very useful to have a block of them that can be incorporated into your drawings. Please visit our website and click on the **Engr./Arch. Resources Tab** and choose the **BeamClamp CAD library**. That will take you directly to all our **2D CAD blocks in both .dwg and .dxf format**.

Cost Analysis for BeamClamp® vs. Traditional Methods

Traditional Drilled & Bolted Method Cost Analysis

Based on pre-drilling the holes of the secondary steel member off site and drilling holes in the existing structure to match on site. The bolts will be 3/4" high tensile.

Connection Requirements	Rate/hr (\$)	Time (hrs)	Step Cost (\$)	Details of Each Step
Engineering	70	0.50	35	Detailing the positions and checking the integrity of the exiting steel after adding holes
Drilling Time of New Steel Off Site	60	1	60	Based on a flange thickness of 1/2" and 1/4 hr per hole
Marking of Steel	40	0.50	20	The time required to mark the steel on site to ensure alignment with secondary member
Site Set Up	60	0.25	15	The time required to access power, get the drilling machine into position
Drilling Time on Site	60	1	60	Based on a flange thickness of 1/2" and 1/4 hr per hole
Positioning and Alignment	60	0.25	15	Alignment of primary and secondary steel holes on site
Assembly Time	60	0.15	9	Very quick to assemble with only four bolts and nuts once steel is aligned
Tightening of Bolts	60	0.20	12	High torques required - allowing for 5 minutes per bolt and nut
Drill Bits	N/A	N/A	15	1 Drill bit
Material Costs (Bolts)	N/A	N/A	16	Four bolts, nuts and washers @ \$4 each
Totals		3.85	\$257.00	

Traditional Welded Method Cost Analysis

Based on making a fully fillet welded connection welded connection of a new hollow section to an existing hollow section structure when both sections have a red oxide or hot dip galvanized corrosion protection.

Connection Requirements	Rate/hr (\$)	Time (hrs)	Step Cost (\$)	Details of Each Step
Engineering	70	0.25	17.50	Not much design work required apart from highlighting the position of weld
Apply for Hot Work Permit	50	0.50	25	The issue time is set at 30 mins - can be longer
Marking of Steel	40	0.25	10	The marking of the steel is at a minimum for a welded connection
Site Set Up	40	0.50	20	Time to move equipment, power cords and get machinery ready
Removal of Corrosion Protection	60	1.0	60	The whole area for the weld needs to be removed by grinding and is time consuming
Performing of Weld (inc. equipment)	110	1.0	110	Based on a certified welder and equipment to make the connection
Fire Watch during and after Weld	40	2.0	80	Fire watchers can be over longer periods but this is set at 2 hours of welding
Touch up of Galvanized Paint	40	0.33	13.2	Replacement of the galv paint will not be as good as the original finish
Non Destructive Testing	60	0.33	19.8	Testing of the weld required to prove load capabilities
Totals		6.16	\$355.50	

BeamClamp® System Connection Cost Analysis

Based on a 3/4" BeamClamp connection that includes the BeamClamp, bolts, nuts, washers and location plate required to make a connection.

Connection Requirements	Rate/hr (\$)	Time (hrs)	Step Cost (\$)	Details of Each Step
Engineering	70	0.25	17.50	The design time is reduced by BeamClamp connection software and engineers
Marking of Steel	40	0.125	5	The marking is reduced as the connection is adjustable
Site Set Up	40	0.25	10	The same as a bolted connection
Assembly Time	60	0.25	15	The assembly will be slightly longer than a standard bolted connection
Tightening of Bolts	60	0.20	12	High torques required as with standard bolting - allowing for 5 minutes per bolt and nut
Material Cost	N/A	N/A	130	The cost of the total materials supplied by LNA Solutions for BeamClamp assembly
Totals		1.1	\$189.50	

When all methods are compared BeamClamp® brings in an average minimum savings of **26%**



BeamClamp® In Action



Installation of a new runway beam for a crane



Hanging of industrial lighting systems

BeamClamp® Rigging Clamps

The **Adjustable Rigging Clamp** is a self adjusting, ready to install rigging clamp capable of safe working loads of up to 5,000 lbs. The shackle connection allows loads to be applied up to 45°. The Adjustable Rigging Clamp can accommodate a variety of flange widths and thickness and is installed without the need for any drilling or welding to the support beam.

The Adjustable Rigging Clamp is available in five (5) standard sizes to accommodate any flange width from 4" to 24". The Adjustable Rigging Clamp is designed to be self adjusting to the flange thickness from as little as 1/8" to as thick as 2-1/2".

The Adjustable Rigging Clamp is designed to accommodate the safe working load not to exceed 5,000 lbs.

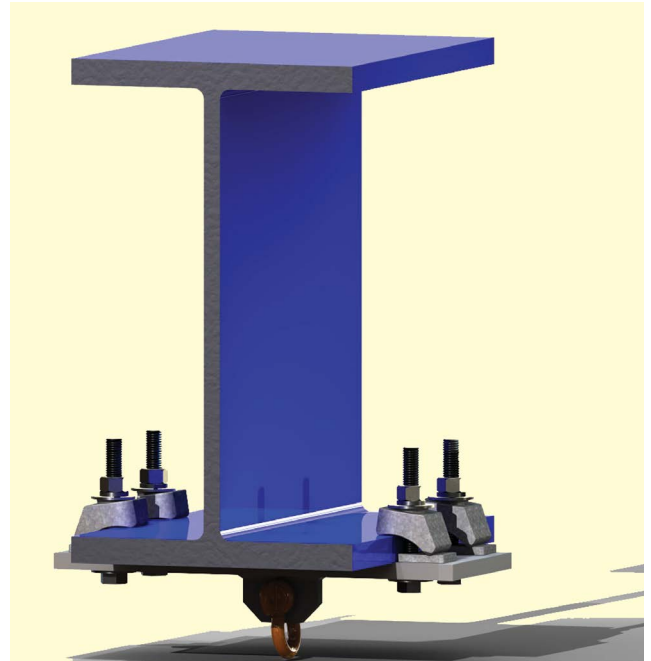

Product Code	Flange Width (in.)	Bolt Torque (ft lbs)	Number of bolts	Safe Working Load (lbs. Do not exceed)
KRC062-A	4" to 8"	109	4	5,000 lbs.
KRC062-B	8" to 12"	109	4	5,000 lbs.
KRC062-C	12" to 16"	109	4	5,000 lbs.
KRC062-D	16" to 20"	109	4	5,000 lbs.
KRC062-E	20" to 24"	109	4	5,000 lbs.

Note: The structural integrity of the existing steelwork should be verified by a licensed structural Engineer

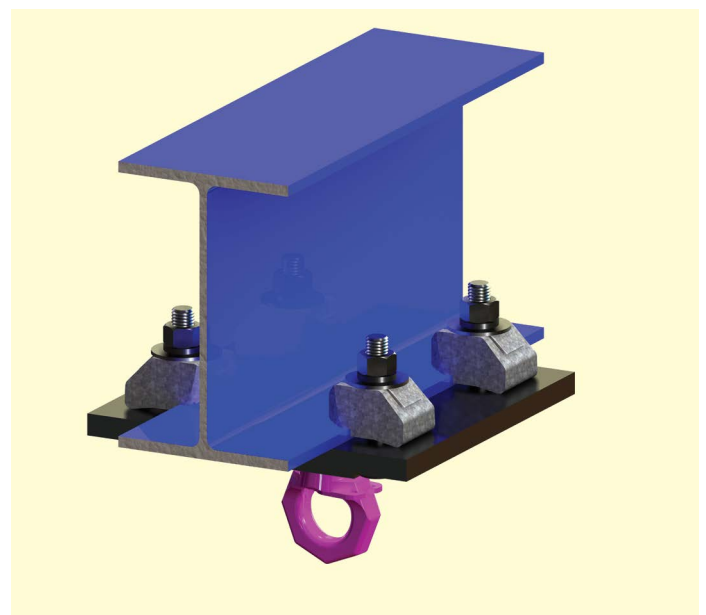
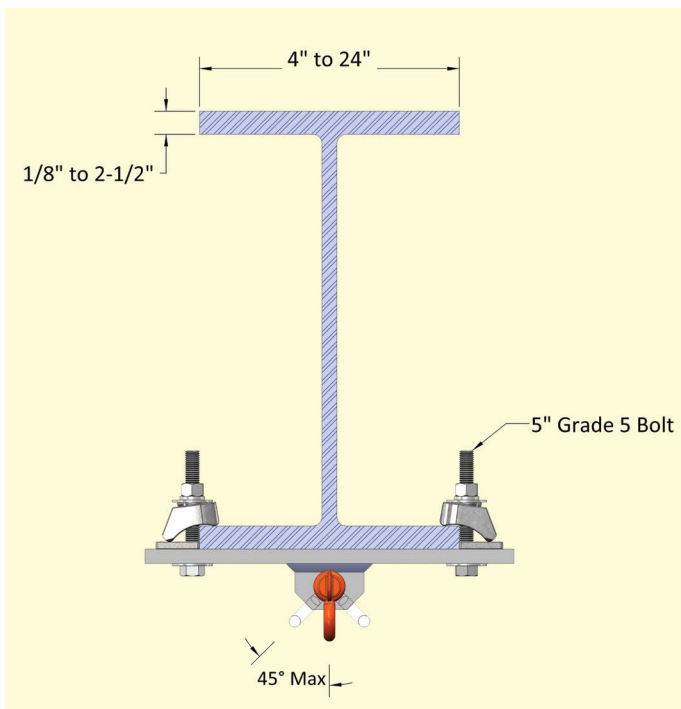

Note: Custom designed rigging and lifting points are available. Please contact LNA Solutions for more information.



BoxBolt® Rigging Clamps

The LNA Solutions BoxBolt® Rigging Clamp is a means of attaching an anchor point to Hollow Structural Sections (HSS) and other structural members when access is available from only one side.

The standard BoxBolt® Rigging Clamp utilizes Hot Dip Galvanized M12 size 1 BoxBolts® and a load ring welded to a custom fabricated anchor plate that allows for Safe Working Loads up to 5000 lbs.

The BoxBolt® Rigging Clamp is easily installed by Drilling a pre-determined set of 13/16" holes into existing steelwork, lining up the anchor plate with the newly drilled holes, inserting and tightening the LNA Solutions BoxBolts® to the specified torque values. There is no more need for site welding, tapping, or strapping.

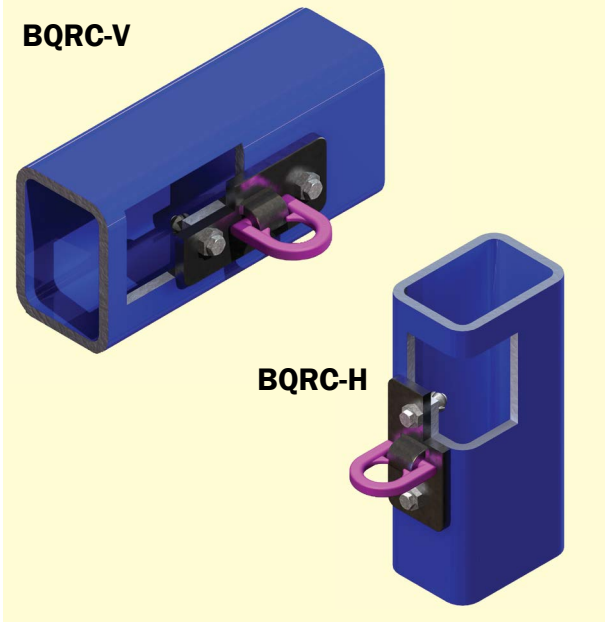

Product Code	Outer Ply Thickness	Hole Size	Safe Working Loads (lbs)	Torque (ft lbs)	Dimensions			Thickness
					W	A	B	
BQRC050-V	1/8" - 1/2"	13/16"	5,000	59	3-1/2"	7-3/4"	5-1/4"	1/2"
BQRC050-H	1/8" - 1/2"	13/16"	5,000	59	3-1/2"	7"	4-1/2"	1/2"

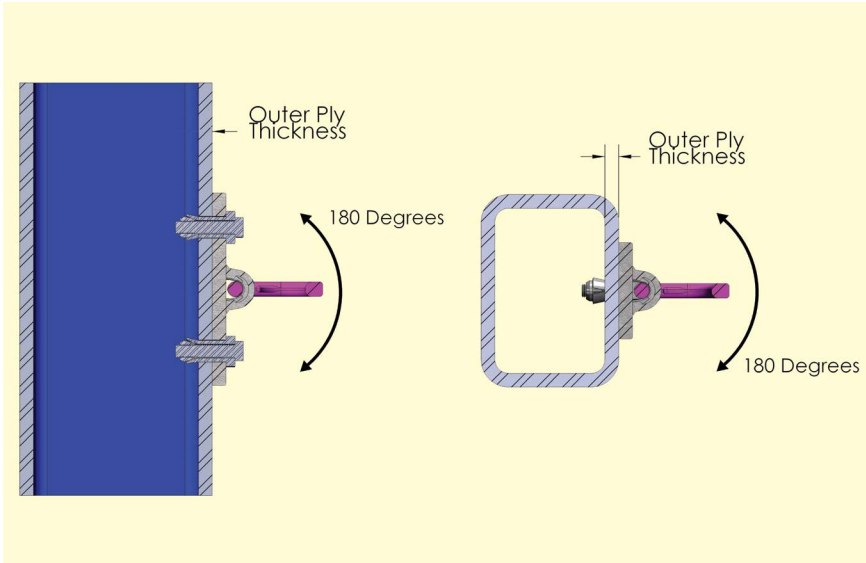
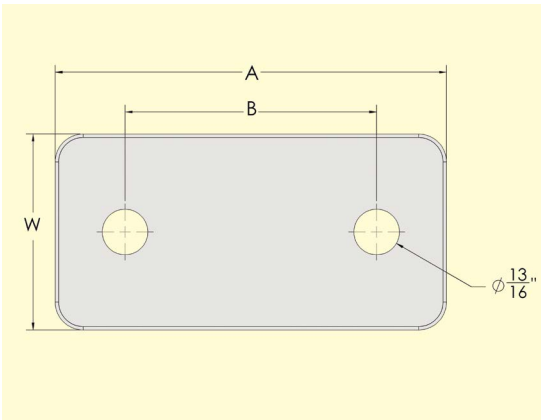

NOTES:

Blind Connection rigging and lifting points can be individually designed for each application and carry a wide range of load capacities (Up to 30 kips)
 Although LNA Solutions guarantees the Safe Working Load of the BoxBolt® Connection, we are not responsible for the structural integrity of the existing steelwork. We recommend that a Licensed Structural Engineer be consulted to establish the capacity of the existing structural member.

BeamClamp® Rigging Clamps

Fast Fit is an off the shelf engineered clamping solution to connect two steel sections together without the need for on-site drilling or welding. All you need to secure two sections together comes in one box. The system comprises a frame which wraps around the edges of the sections and slides into place to provide a position for the clamps to be secured.

The system allows for varying angles that can be easily achieved by sliding the beams relative to each other.

The Fast Fit system delivers a guaranteed connection every time without the need for on-site testing or relying on the skills of the installer. No removal of the protective coatings on the existing steel or holes is required to make a connection. All that is required to complete a connection are simple hand tools and semi-skilled labor.



A KEE SAFETY PRODUCT



Why use Fast Fit and what benefits does it provide?

Features	Advantages	Benefits
No drilling or welding to existing structure	No on-site power required	Reduced installation time and no need to relocate cables, hoses etc.
Clamps directly to the existing structure	No damage to corrosion protection and no weakening of the steel	Flexibility and reduced on-site installation time
No heat or sparks generated	No hot work permit is necessary	Reduction in installation cost and administration time
No additional safety considerations	Safe for use in hazardous conditions	Peace of mind that the connection can be made without any hazards created
Installation by semi-skilled labor	No need for specialist skills or equipment	Reduction in labor and hire costs
Easy re-alignment of steel members	Eliminates remedial work due to steel miss alignment	Reduction in labor costs and provides on site flexibility
Tested at a third party test facility	Third party tested for use in tensile and frictional applications	Confidence that the connection will perform as stated in the literature
Electro Galvanised Finish	Corrosion protection is provided as standard meaning no post touch up or finish	Reduction in installation time and confidence in the finish
Suits a wide range of steel sections	A one stop shop for most connections	Reduced sourcing costs for users
Guaranteed loading and factor of safety	No on-site testing required or reliance on the skill of the installer	Reduction in installation time and peace of mind that every connection will perform as stated
Flush steel to steel connection	No location plate or spacers required	Saves time on re-design due to height level changes



Fast Fit Technical Information

Product Code	Bolt dia.	Bolt grade	Bolt length (in.)	Overall size (in.)	Flange thickness (in.)	Flange width (in.)	Tightening torque (ft/lb)	Tensile load (4 bolts) (lbs)	Frictional load (4 bolts) (lbs)
BCFF16	M16 (5/8")	8.8	5	13 3/4 x 13 3/4	1/8 to 1	2 1/2 to 7 1/2	110	4763	1142

Factor of Safety

The above loading data has a 5 to 1 Factor of Safety.

Achievable Angles

The Fast Fit system is designed to allow sections of different widths to be connected at varying angles. The table below provides information on what angles can be achieved.

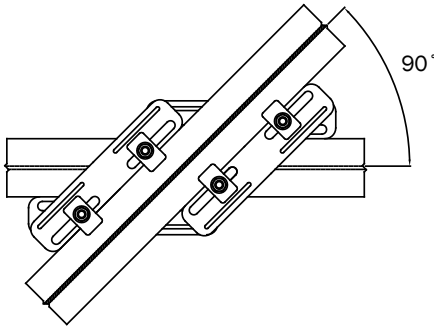

Flange width	Top section											
	2.5"	3.0"	3.5"	4.0"	4.5"	5.0"	5.5"	6.0"	6.5"	7.0"	7.5"	
Bottom Section	2.5"	45	45	50	50	50	55	55	60	65	70	75
	3.0"	45	45	50	50	50	55	55	60	65	70	75
	3.5"	50	50	50	50	55	55	55	55	65	70	75
	4.0"	50	50	50	50	55	55	55	55	65	70	75
	4.5"	50	50	50	50	50	55	55	55	65	70	75
	5.0"	55	55	55	55	55	55	55	55	65	70	75
	5.5"	55	55	55	55	55	55	55	60	65	70	75
	6.0"	60	60	60	60	60	60	60	65	65	70	75
	6.5"	65	65	65	65	65	65	65	65	65	70	75
	7.0"	70	70	70	70	70	70	70	70	70	75	75
7.5"	75	75	75	75	75	75	75	75	75	75	80	

Installation Instructions

The Fast Fit system can be fully installed in under 5 minutes which saves time compared to traditional welding or drilling methods. Following the steps below will give a fully guaranteed connection.

STEP 1 - Install the framework of plates around the two sections to be connected.



STEP 2 - Rotate the open side of the plate around the sections so that the frame is complete.



STEP 3 - Insert one set of clamps through each corner ensuring they are positioned as in step 4.

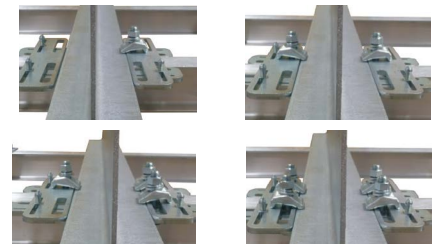

STEP 4 - The front and back edge of the clamps should run parallel with the steel sections.



STEP 5 - **Hold** the head of the bolt with a standard wrench and tighten the nut with a torque wrench to the recommended torque stated above. Repeat this for all four bolts.

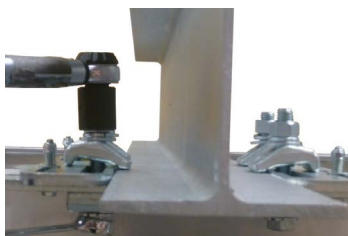

IMPORTANT CHECK!

Always check the clamps have been installed the correct way around. See diagrams below:

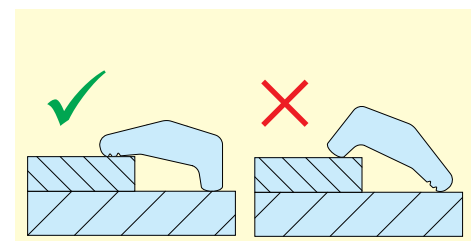

Floor Connections

FloorFix HT

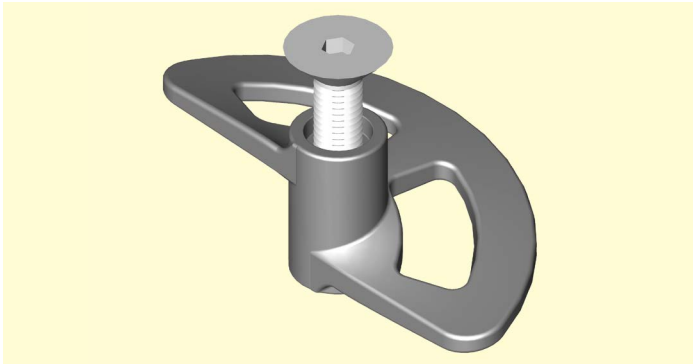

- Allows for +/- 1/4" construction tolerance
- Can clamp up to 1" thick steel as standard
- Hot Dip Galvanized finish as standard
- Easily installed from the top side only
- No drilling, tapping or welding required
- Allows easy repositioning or lifting of floor plate
- No special tools or skilled labor required
- No access to the underside required
- Tested for vibration conditions at TÜV

FLOORFIX HT has been developed following customer feedback to provide a clamp with increased functionality to suit a wider range of applications. **Floorfix HT** is designed to clamp flooring plate to supporting steel from the topside only without the need for time consuming on-site drilling, tapping, bolting or welding. It works on a cam mechanism that can be operated using a basic hexagon key drive.

Floorfix HT is so named because it allows steel erectors a high degree of tolerance. It retains all the benefits of our widely renowned original design but is far more user friendly. **Floorfix HT** allows for floor plates to be connected to new steel that is erected within +/- 1/4" of its intended position. It is capable of connecting to steel flanges from 1/8" - 1" without the need for additional packing pieces.

Plate Preparation

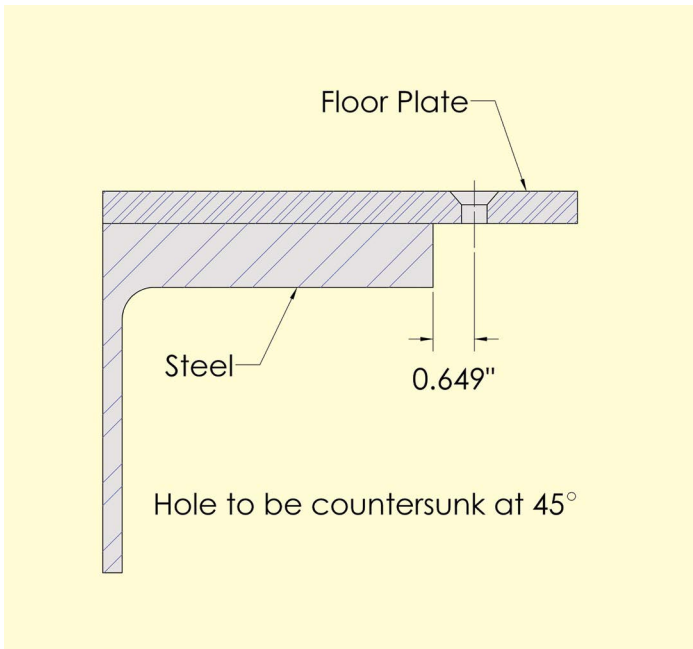

Product Code	Screw Diameter	Floor Plate Thickness		Steel Flange Thickness		Tightening Torque (ft lb)
		min	max	min	max	
FLOORFIXM08HT	5/16	1/8	1/2	1/8	1	15
FLOORFIXM10HT	3/8	3/16	1/2	1/8	1	18
FLOORFIXM12HT	1/2	1/4	1/2	1/8	1	22

Floorfix HT has been tested for vibration conditions to simulate the most common applications where the clamps would be used, e.g. **walkways, machine shops** and **press shops**. Please ask our technical department for a copy of the certificate, should you require this.



FloorFix HT Installation Instructions

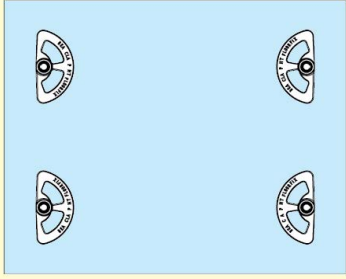

Step 1 Assemble the **Floorfix HT** to the underside of the floor plate making sure the markings “THIS WAY UP” are facing the underside. Loosely tighten the bolt making sure the flat edge of the clamp is in line with the edge of the steel it is going to connect to.

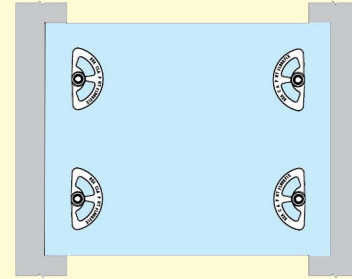

Step 2 Lower the plate in to position over the supporting steelwork.

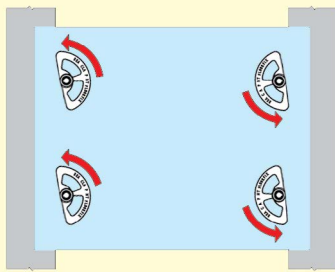

Step 3 Once the floor plate is in the desired position, rotate the countersunk bolt one full turn counter-clockwise.

Note 1 We recommend using the 1/2” version when vibration conditions are incurred as this can be tightened to a higher torque.

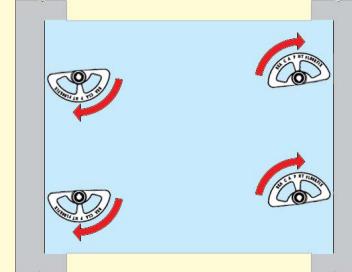

Step 4 Tighten the countersunk screw until the plate is secured. For guaranteed performance, use the recommended tightening torques given in the table on page 34.

Note 2 If the steel being connected to is thicker than 1” then we can supply packers and a longer bolt to increase the clamping range.

FloorFix

- Installation from one side only
- Manufactured from Ductile Iron
- Hot Dip Galvanized
- Allows for easy maintenance

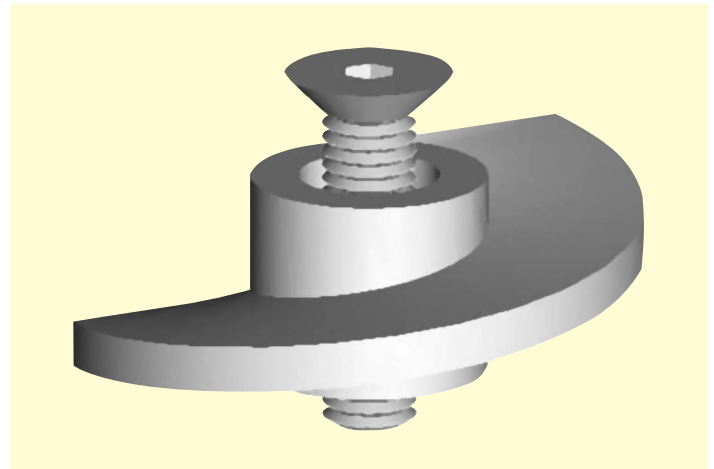
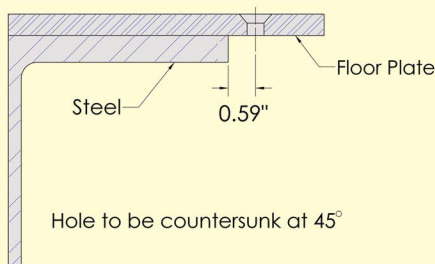

Product Code	Screw Diameter	Floor Plate Thickness		Steel Flange Thickness		Tightening Torque (ft lb)
		min	max	min	max	
FLOORFIXM08	5/16	1/8	1/2	1/8	5/8	15
FLOORFIXM10	3/8	3/16	1/2	1/8	5/8	18
FLOORFIXM12	1/2	1/4	1/2	1/8	5/8	22

Gratefix



- **Mechanical Galvanized Malleable Iron**
- **Stainless Steel Grade 304 and 316**
- **Easily installed from the top side only**
- **No drilling, tapping or welding required**
- **Allows easy repositioning or lifting of grating**
- **No special tools or skilled labor required**
- **No access to the underside required**
- **Tested for vibration conditions at TÜV**

GRATEFIX is a heavy-duty clamp that allows open floor grating to be clamped to the supporting steel from the topside only. The **Gratefix** features a cast bottom piece that provides additional strength to clamp on to the steel flange. The Gratefix is available in several different styles to suit the grating dimensions and the application.

GF3S08

Pressed Top Bracket – Stainless Steel to EN 10088 Grade 1.4301 (AISI 304)
Cast Bottom Bracket – Stainless Steel to ASTM A743 Grade CF-8 (S30400)

GF1S08

Pressed Top Bracket – Stainless Steel to EN 10088 Grade 1.4401 (AISI 316)
Cast Bottom Bracket – Stainless Steel to ASTM A743 Grade CF-8M (S31600)

GF1G10 (All Lengths)

Pressed Top bracket – Material: Mild steel to EN 10025 grade S275
Cast Bottom Bracket – Material: Malleable iron to BS 1562: Grade EN GJMB-300-06
Both finished in: Mechanical Galv to ASTM B695

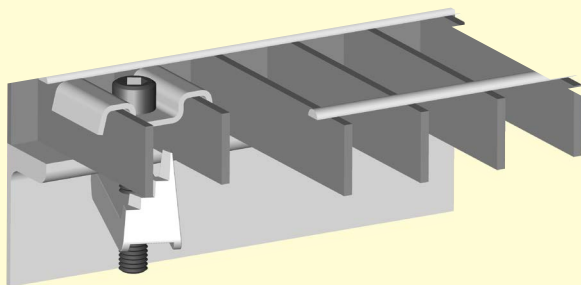

Product Code	Material/Finish	Screw Diameter	Flange Thickness, T	Grating Bar Depth		Grating Bar Width	Grating Bar Spacing	Body Width	Tightening Torque (ft lb)
				Min.	Max.				
GF3S08	304 Stainless Steel	5/16	1/8 - 3/4	7/8	1-1/2	5/16 - 3/8	3/4 - 1-7/8	5/8	4
GF1S08	316 Stainless Steel	5/16	1/8 - 3/4	7/8	1-1/2	5/16 - 3/8	3/4 - 1-7/8	5/8	4
GF1G10	Galvanized Malleable Iron	3/8	1/8 - 3/4	3/4	*2 minus T	1/8 - 1/4	1-3/16	3/4	8
GF1G10-75	Galvanized Malleable Iron	3/8	1/8 - 3/4	1-5/8	*2-5/8 minus T	1/8 - 1/4	1-3/16	3/4	8
GF1G10-90	Galvanized Malleable Iron	3/8	1/8 - 3/4	2-1/8	*3-1/8 minus T	1/8 - 1/4	1-3/16	3/4	8
GF1G10-100	Galvanized Malleable Iron	3/8	1/8 - 3/4	2-5/8	*3-5/8 minus T	1/8 - 1/4	1-3/16	3/4	8
GF1G10-110	Galvanized Malleable Iron	3/8	1/8 - 3/4	3-1/8	*4-1/4 minus T	1/8 - 1/4	1-3/16	3/4	8

* Grating Bar Depth is variable dependent on thickness of the flange.

Installation

Custom solutions also available. Please contact LNA Solutions for more information.

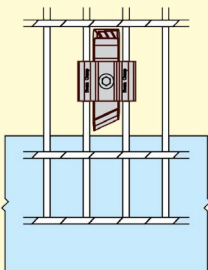

Step 1

Lower the GRATEFIX through the open part of the grating, ensure the bracket is seated over the adjacent bearing bars.

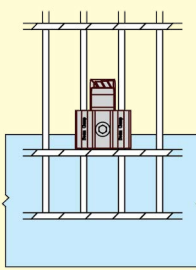

Step 2

Slide the GRATEFIX towards the supporting steelwork flange as far as it will go to ensure maximum clamping force.

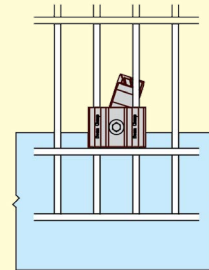

Step 3

Tighten the screw and ensure that the lower casting rotates until one of the steps locates on the bearing bar.



Grating Clip

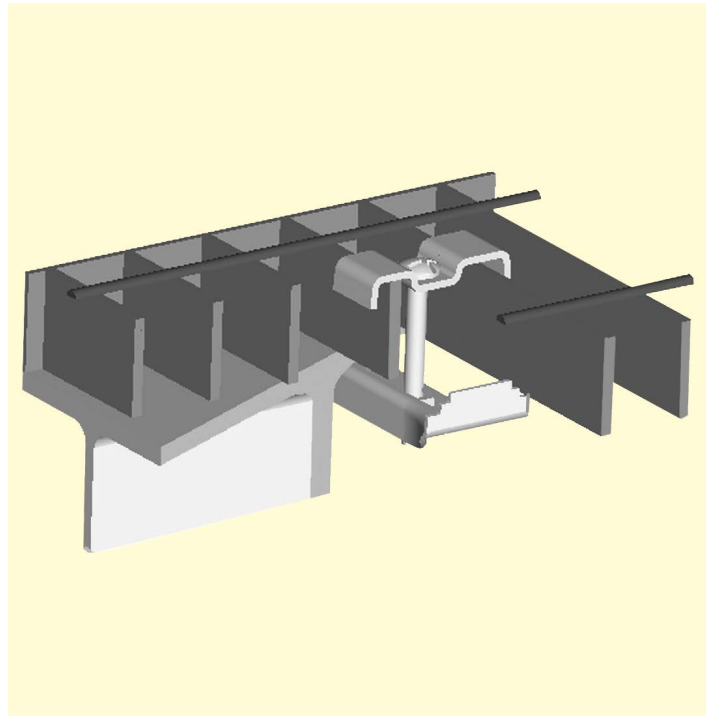
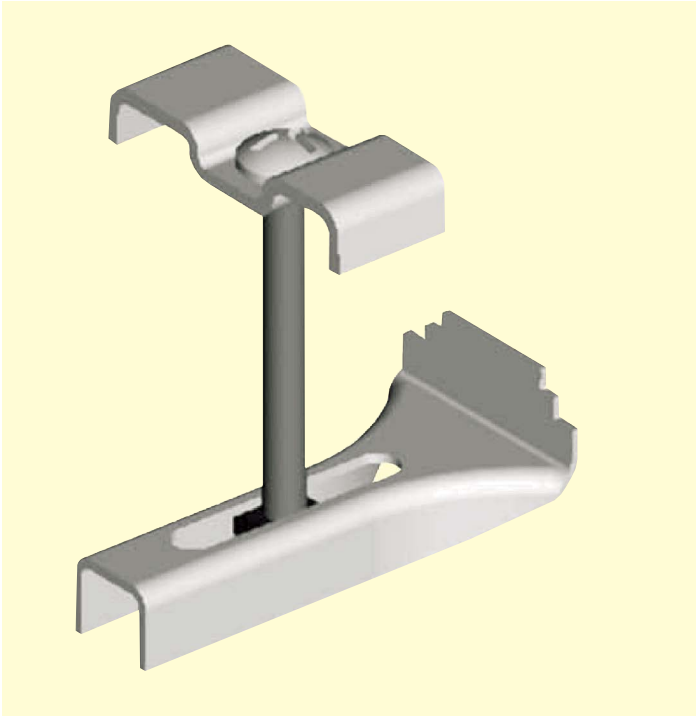

The **GRATING CLIP** is the most common style of clip used for clamping down open steel flooring. It provides a quick and cost effective method of clamping. It is **Hot Dip Galvanized** and comes standard with a top bracket to suit **1-3/16" - 1-5/8" ctrs grating bars.**

Product Code	Screw Dia	Flange Thickness, T	Grating Bar Spacing		Grating Bar Depth
			Min.	Max.	Max.
GRAT 1G08	5/16	1/8 - 3/4	1-3/16	1-5/8	2-1/4 minus T



G-Clip GG

Fastens Bar Grating to Structural Members



The G-CLIP GG fastener is a galvanized, carbon steel grating fastener for securing steel grating to existing steel. Hand tools can be used for ease of installation. To install, simply drop the clip in place above the grating, slide the clip toward the beam flange, and tighten the G-CLIP fastener using a 7/16" nut driver. Clips are also available in stainless steel for more corrosive environments.



Custom sizes are available on a special order basis.

product code	bolt diameter (in.)	grating thickness (in.)	tightening torque (ft. lb.)
KSGG-1A	1/4	1	5
KSGG-1B	1/4	1 1/4	5
KSGG-1C	1/4	1 1/2	5

G-Clip GM

Mounts Devices onto Floor Grating



The G-CLIP GM fastener is a galvanized steel fastener used to mount devices onto the grating surface. The G-CLIP GM fastener consists of three parts; the stamped top, threaded stud, and the lower body assembly. The lower body assembly holds in place a 1/2" nut, making installation hassle-free. Install using a spanner wrench or an adjustable open end wrench to tighten in place. This clip eliminates the need for J-bolts. The G-CLIP GM fastener can withstand 1,000 pounds of direct upward pull force with no distortions.

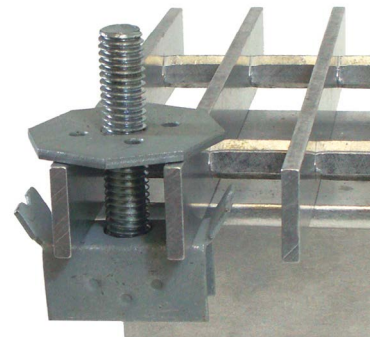

Lock washer and second threaded nut needed in installation not provided.

product code	stud diameter (in.)	stud length (in.)	body width (in.)
KSGM-12	1/2	3	7/8



The lower body assembly is constructed with a specially designed stamped wing component that keeps a 1/2" nut from turning.

Testing

As previously mentioned the **Floorfix HT**, **FloorFix** and **Gratefix** have been tested in conditions to simulate the typical applications of these clamps. The clamps were tested for performance in both vertical and horizontal axis to ensure they did not work loose when subjected to vibration conditions. The test set-up can be seen below. The certificates are available on request.



Vertical Axis Test

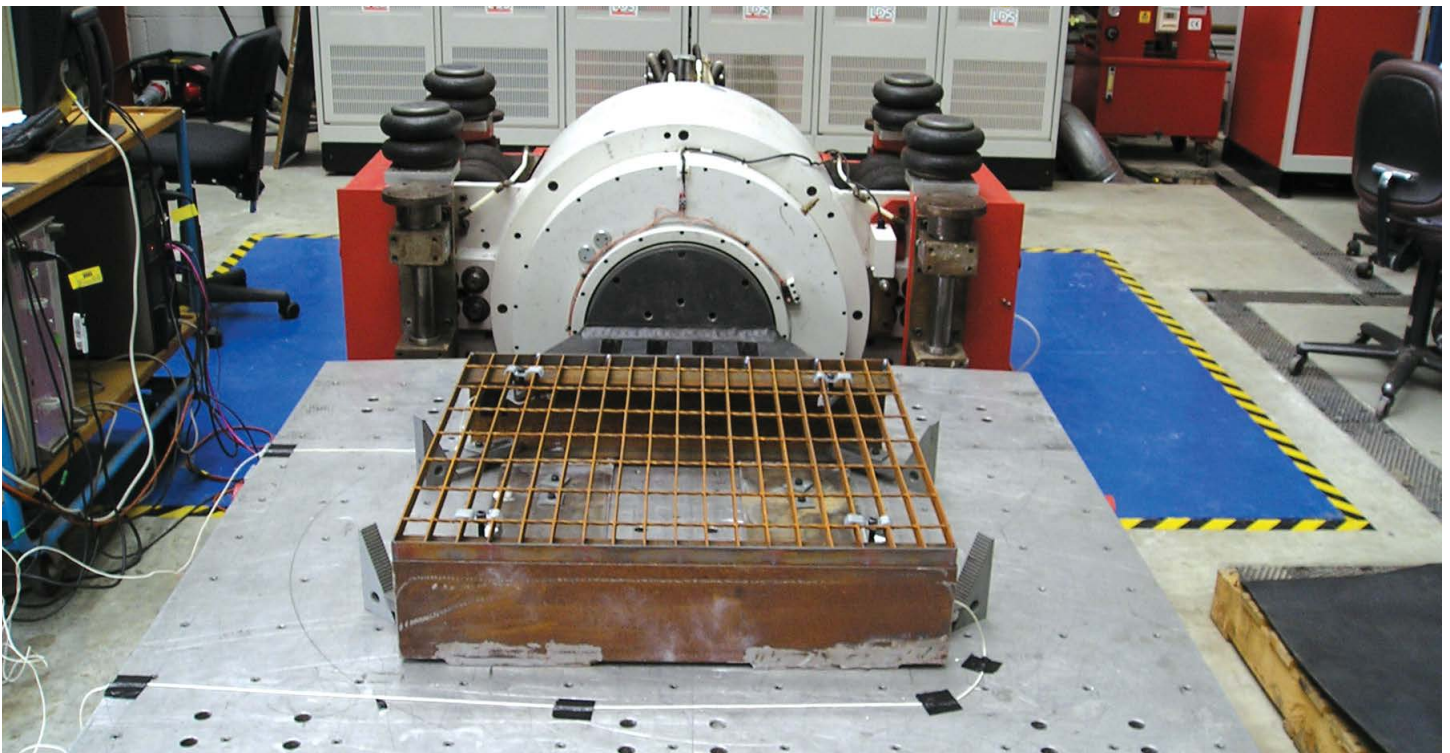

Horizontal Axis Test

Service Support Solutions

Type BL Flange Clamp

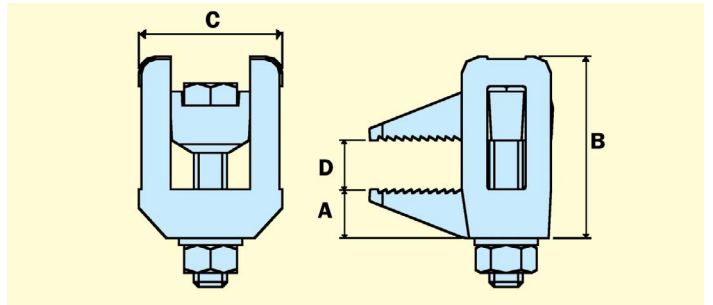
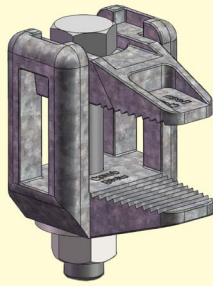

The **BL Flange Clamp** is a versatile clamp used for a wide variety of applications. It can be used with clips and brackets underneath the nut and washer side for connecting conduit or even pipe work. It can also be used for clamping down the lids of pressure vessels or clamping steel together without the need for drilling or welding.

The clamp is tested for tensile and lateral loads. Please see data sheet below. The recessed part is specifically designed to grip the head of a bolt or nut which means the clamp can always be connected by using a single wrench. The central bolt can be replaced with other threaded items such as threaded rod, eyebolts or J-bolts to provide a suspension element.

The Safe working loads are based on assemblies tested in typical conditions for an individual clamp unless stated.

Product Code	A	B	C	D	Tightening Torque (ft lb)	Tensile Load in Line with Rod (lbs)	Tensile Load at Nose (lbs) (per pair)	Lateral Load (lbs)
BL1G08A	1/2	1-3/4	1-9/16	0 to 13/16	7	225	1664	56
BL1G10A	9/16	2-5/16	1-7/8	0 to 1-3/16	14	562	2098	90
BL1G12A	5/8	2-9/16	2	0 to 1-3/8	29	1124	2473	135
BL1G16A	13/16	3-3/4	2-5/16	0 to 2-3/16	66	1686	4571	157
BL1G20A	7/8	4-9/16	2-5/8	0 to 2-3/4	132	2023	5246	169
BL1G24A	1	5-3/4	2-15/16	0 to 3-3/4	147	2360	7718	180

All of the above loads have been subject to a **3:1 Factor of Safety**. Do not exceed the **Safe Working Load (SWL)** specified.

Hemispherical Cups and Washers - BV1 & BU1

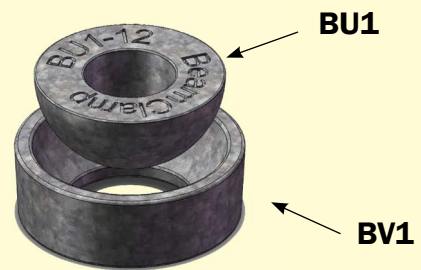
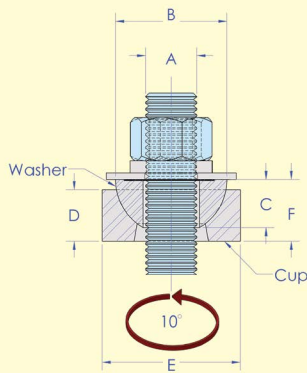

- Allows a swing of **10°** in all directions
- Prevents the need to bend threaded rod
- Provides pivotable element for adjustment

The hemispherical washers (**BU1**) and cups (**BV1**) provide a pivotable action when used with threaded rod. They allow a 10 degree swing in all directions from vertical and when used in pairs can provide a locked connection as shown on page 39. Typical applications would be connecting to a roof rafter where the threaded rod needs to be hanging perpendicular to the floor or for making a ball socket on the legs of air conditioning support frames to allow adjustability for sloping roofs.

Washer Product Code	Cup Product Code	A Bolt Dia	B	C	D	E	F	Tensile Load (lbs)
BU1G08	X	5/16	7/8	5/16	X	X	X	281
BU1G10	BV1G10	3/8	1	3/8	1/2	1-1/4	9/16	562
BU1G12	BV1G12	1/2	1-1/8	1/2	1/2	1-3/8	9/16	926
BU1G16	BV1G16	5/8	1-5/16	9/16	5/8	1-5/8	3/4	1484
BU1G20	BV1G20	3/4	1-3/4	3/4	3/4	2-1/8	15/16	2151
BU1G24	BV1G24	1	2-1/4	1	1	2-5/8	1-1/8	2866

All of the above loads have been subject to a **5:1 Factor of Safety**.



Service Support Application Examples

40

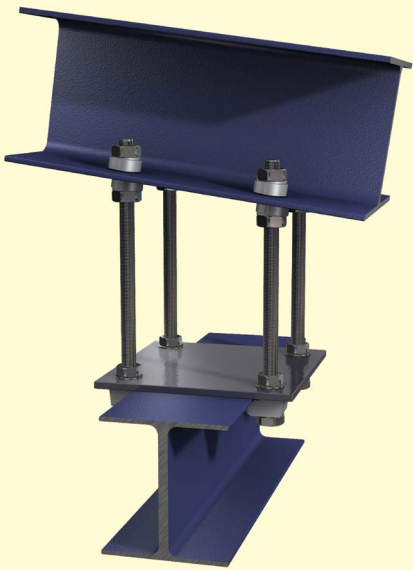

41

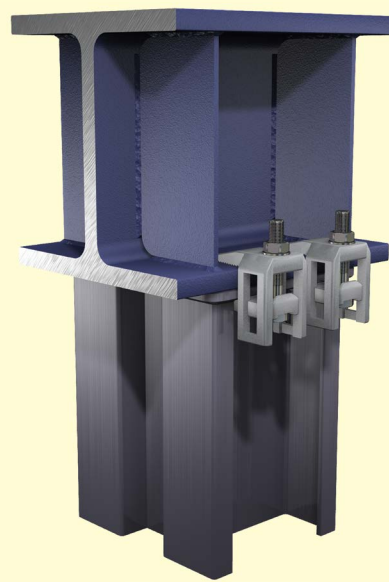

42

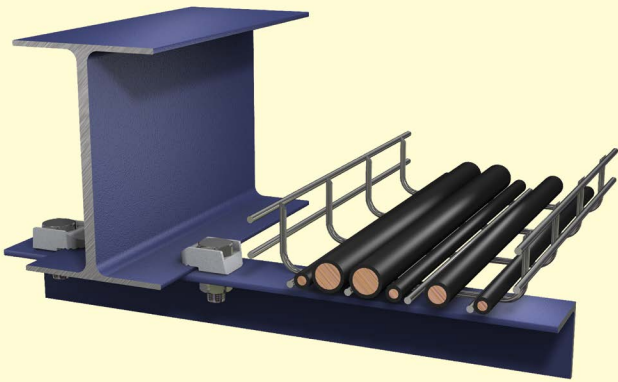

43

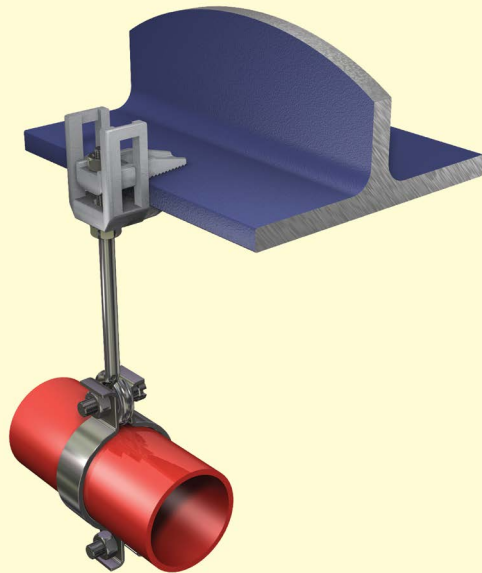

44

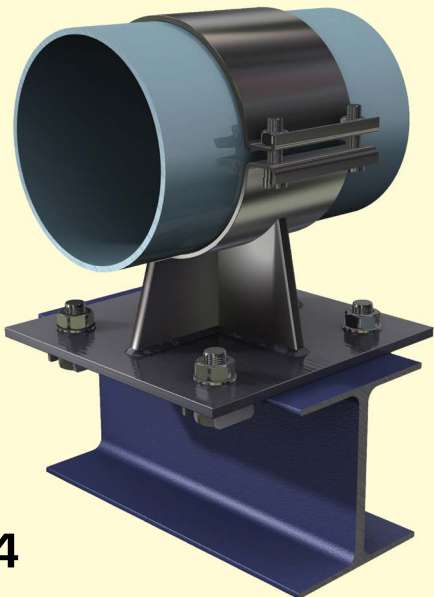

45

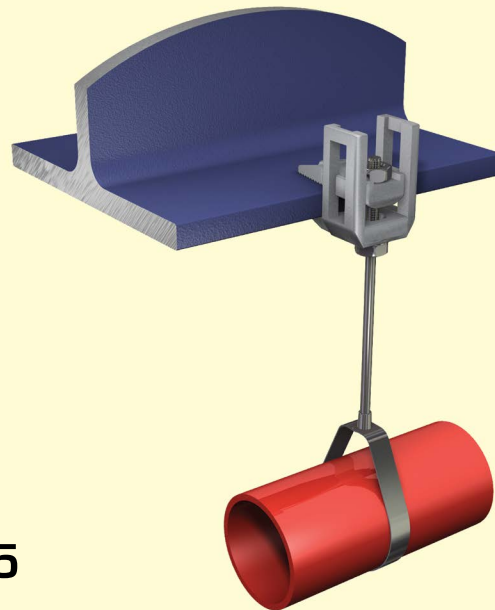



LNA Solutions, Inc.

3924A Varsity Drive
Ann Arbor, MI 48108

Tel: (888) 724 2323

Fax: (734) 677 2339

Email: inquires@LNAsolutions.com

www.LNAsolutions.com



Providing Structural Steel Connection Solutions in the US since 1995

LNA Solutions are authorized users of BEAMCLAMP and BOXBOLT, registered trademarks of Access Technologies Limited, a subsidiary of Kee Safety International Ltd. While every effort has been made to ensure the accuracy of the information contained in this leaflet Access Technologies Limited cannot be held responsible for any errors or omissions. Access Technologies Limited reserve the right to alter or withdraw products without prior notice. Access Technologies Limited accept no responsibility for any loss or damage arising from improper use of their products.

© 2012 LNA Solutions Inc. All Rights Reserved